



INNOVATIVE SOFTWARE SOLUTIONS
www.hermes-softlab.com

eUprava

Andja Komšo, Hermes Softlab d.d.



- ▶ **Kaj je eUprava?**
- ▶ **eUprava za boljšo upravo**
- ▶ **Novi elektronski poslovni model**
- ▶ **Elektronsko davčno poslovanje**
- ▶ **Stanje Slo eUprave**
 - Kako je nastajala
 - Na kateri stopnji je
 - Kateri so ključni segmenti
 - Kdo so kreatorji eUprave
 - Kaj je dobro – mednarodno primerljivo
 - Kaj bi lahko bilo boljše – ni za ponoviti
 - Kako to delajo drugje
- ▶ **Kam greš Slovenija?**
- ▶ **Merjenje učinkovitosti – benchmarking**

- ▶ **“E-Government” refers to the use by government agencies of information technologies (such as Wide Area Networks, the Internet, and mobile computing) that have the ability to transform relations with citizens, businesses, and other arms of government.**
- ▶ **These technologies can serve a variety of different ends:**
 - better delivery of government services to citizens,
 - improved interactions with business and industry,
 - citizen empowerment through access to information, or
 - more efficient government management.
- ▶ **The resulting benefits can be less corruption, increased transparency, greater convenience, revenue growth, and/or cost reductions.**

<http://web.worldbank.org/...702586,00.html>

- ▶ **Traditionally, the interaction between a citizen or business and a government agency took place in a government office.**
- ▶ **With emerging information and communication technologies it is possible to locate service centers closer to the clients.**
- ▶ **Such centers may consist of:**
 - an unattended kiosk in the government agency,
 - a service kiosk located close to the client, or
 - the use of a personal computer in the home or office.
- ▶ **Analogous to e-commerce, which:**
 - allows businesses to transact with each other more efficiently (B2B) and
 - brings customers closer to businesses (B2C),
- ▶ **e-government aims to make the interaction between:**
 - government and citizens (G2C),
 - government and business enterprises (G2B),
 - and inter-agency relationships (G2G)
- ▶ **more friendly, convenient, transparent, and inexpensive**

<http://web.worldbank.org/...702586,00.html>

We are here to serve to governed not the governing.

eGovernment: More than automated government

eGovernment is more about government
than about “e” ...

(elektronski) poslovni modeli Globalno povezovanje

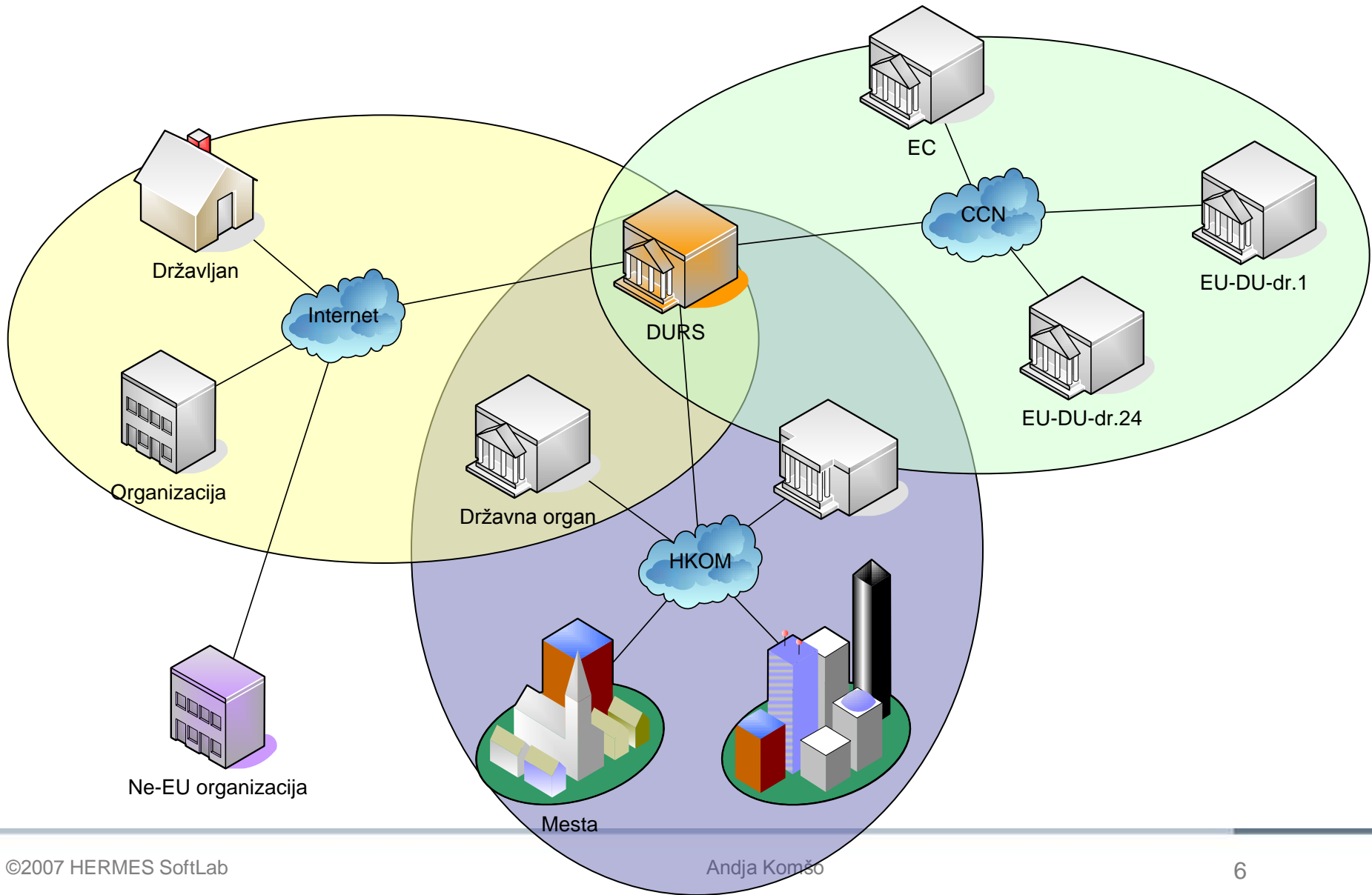

One-stop-shop modeli

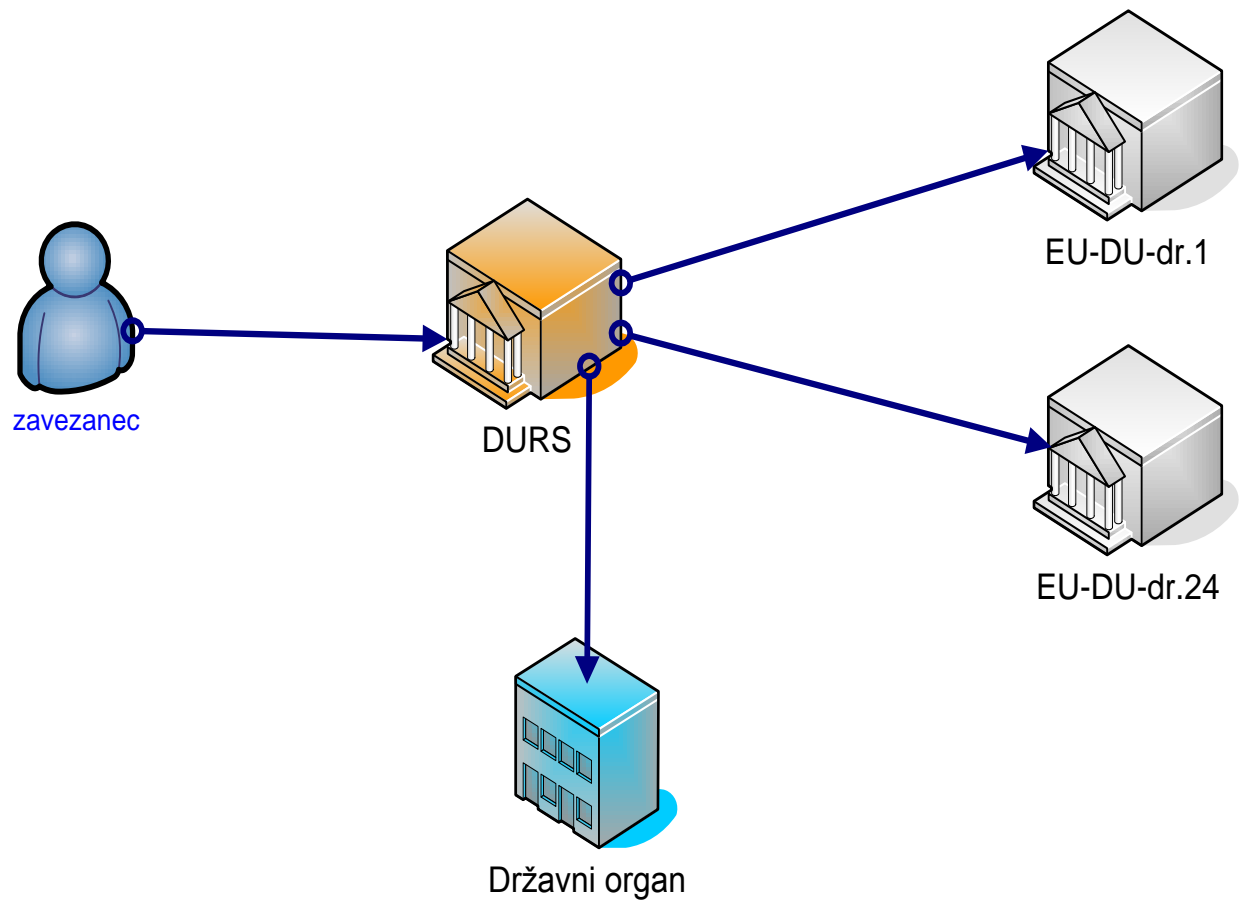



eVAT: obdavčitev EC v EU

Kompleksne integracije

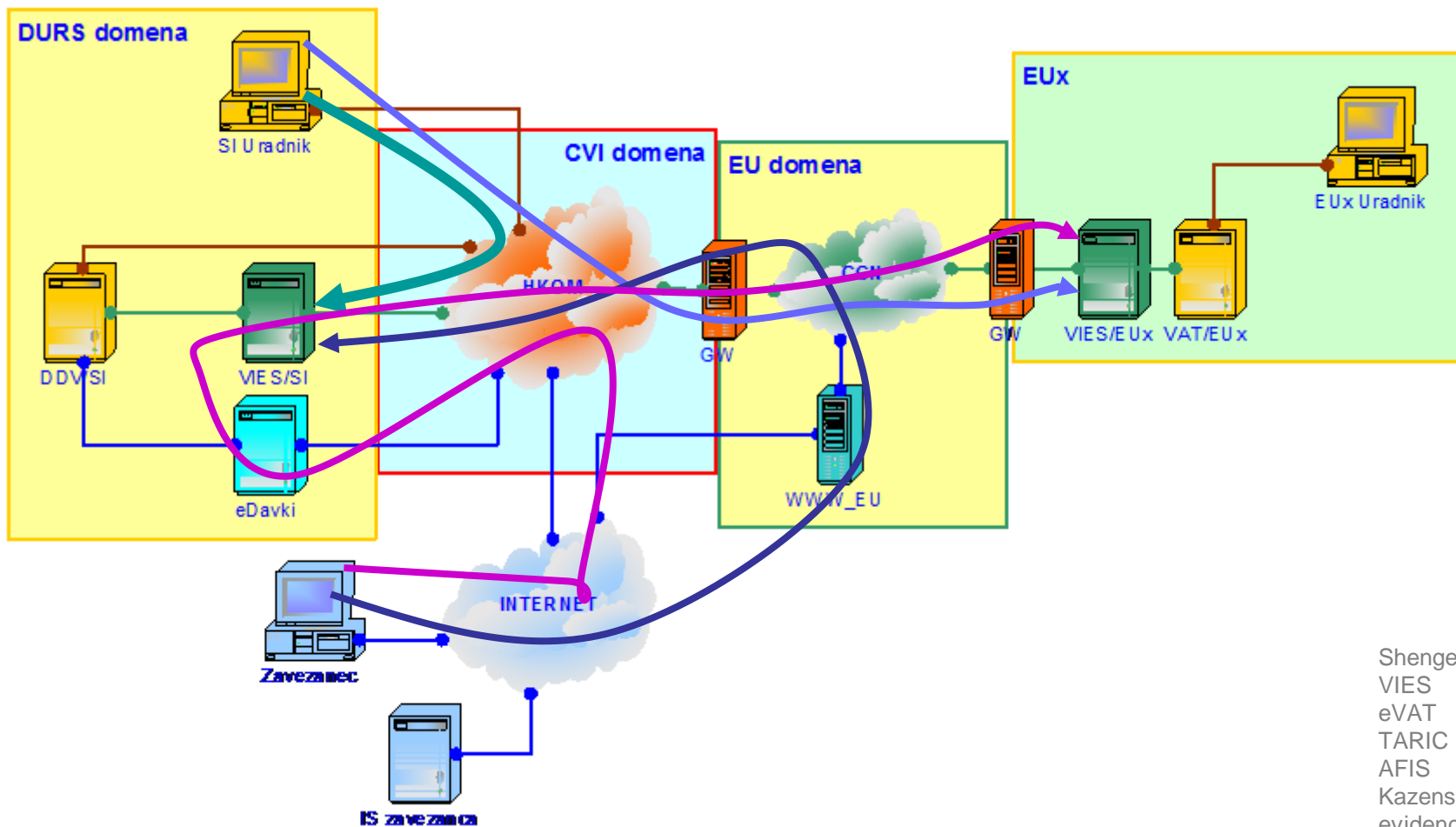

Shengen
VIES
eVAT
TARIC
AFIS
Kazenska
evidenca

Poenostavitve procesov Vlaganje dokumentov osebno

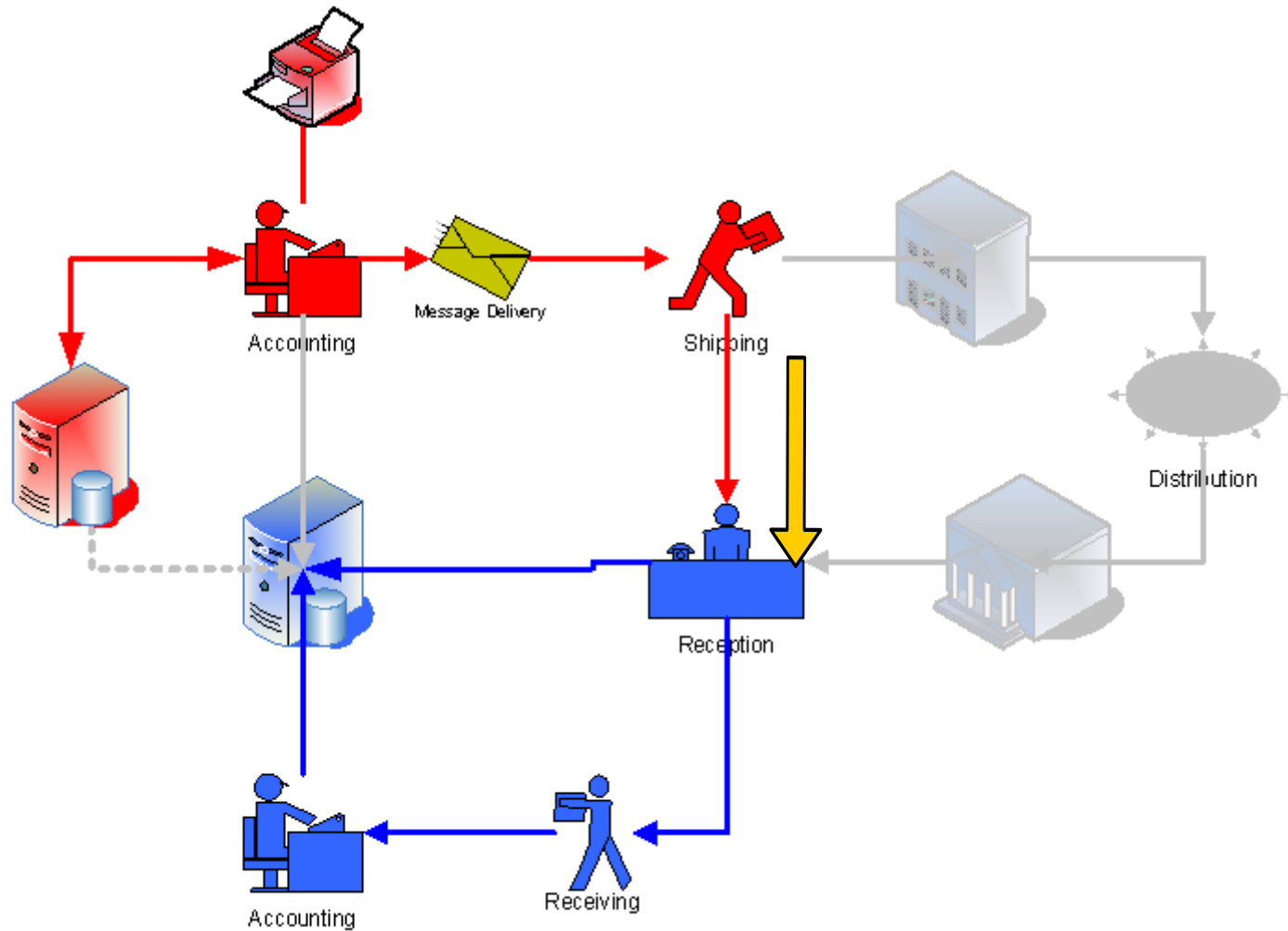

Poenostavitve procesov Interaktivno elektronsko poslovanje

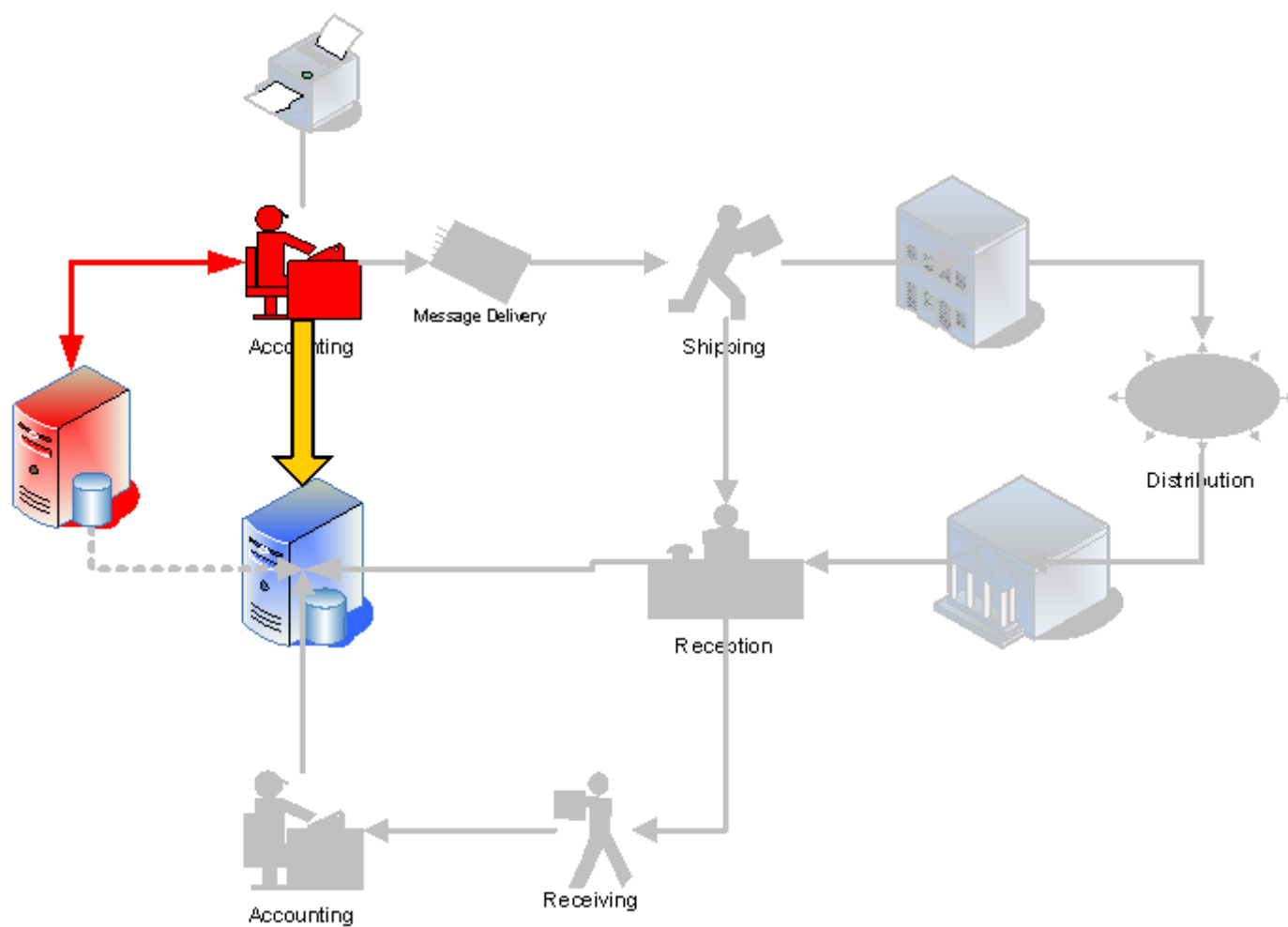

Poenostavitve procesov

Čisto elektronsko poslovanje

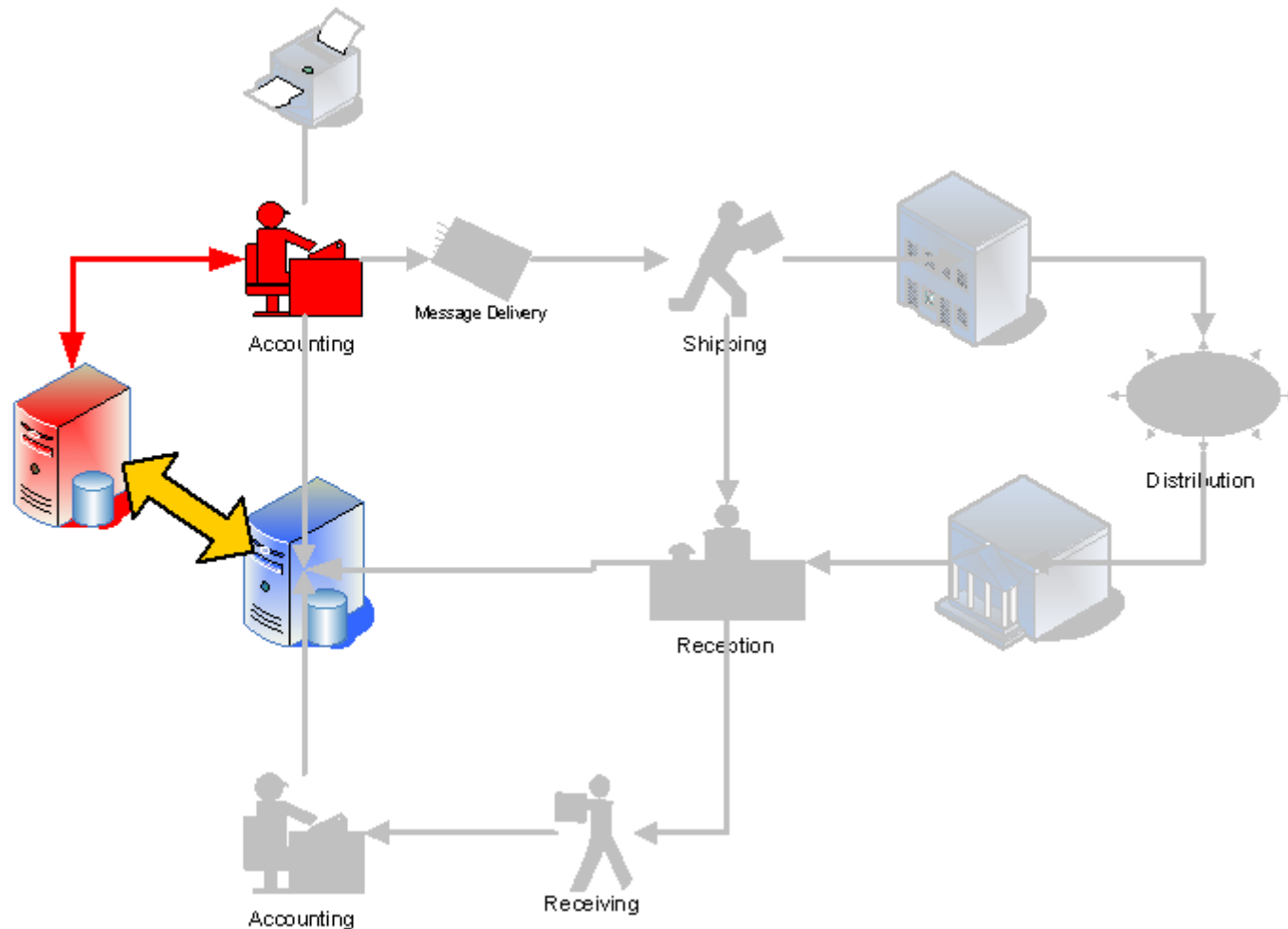

Poenostavitev procesov Klasični proces

Davčni obračuni: Proces izpolnjevanja, dostave in kontrole

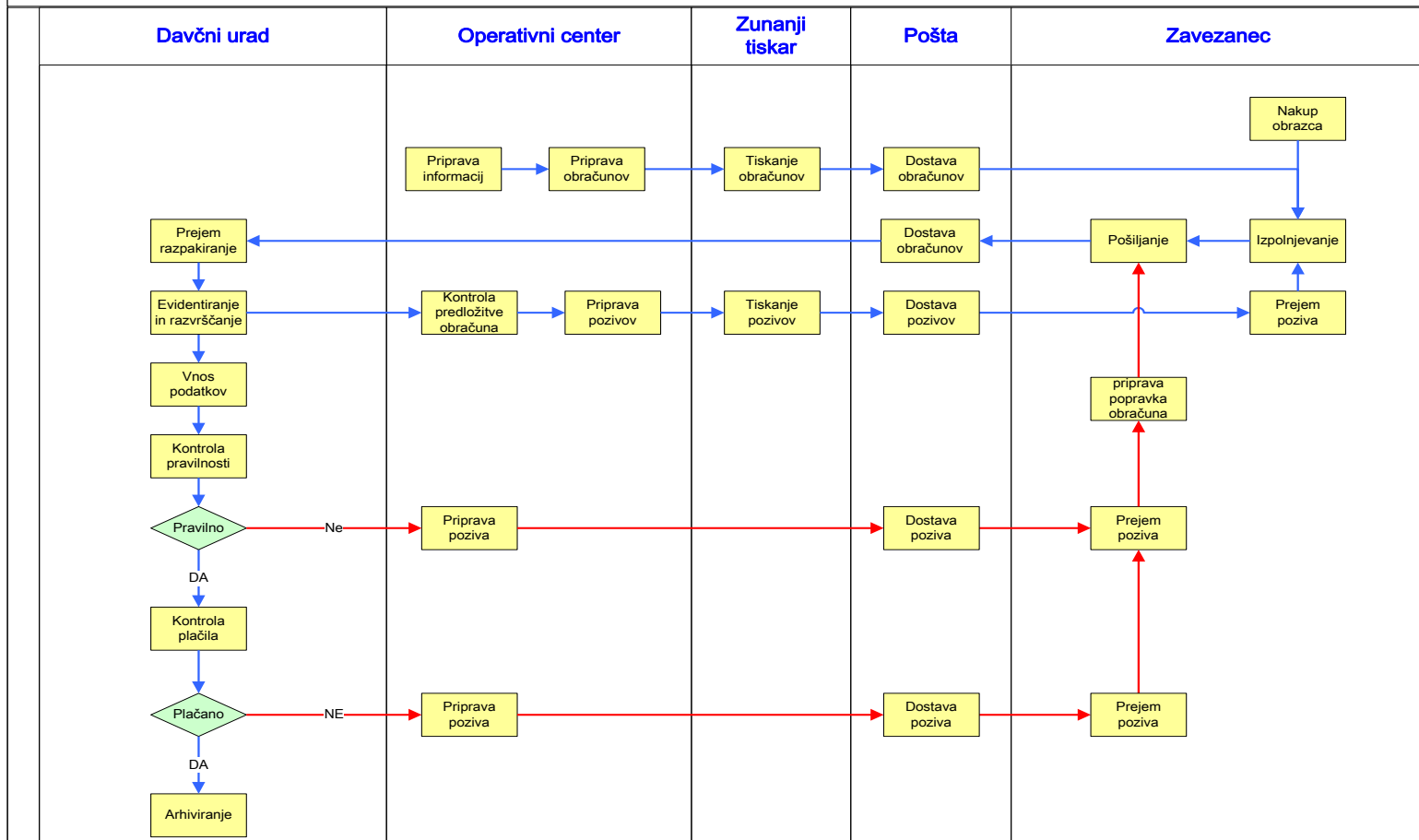

Na ePoslovanju temelječ proces

Davčni obračuni: Proces izpolnjevanja, dostave in kontrole

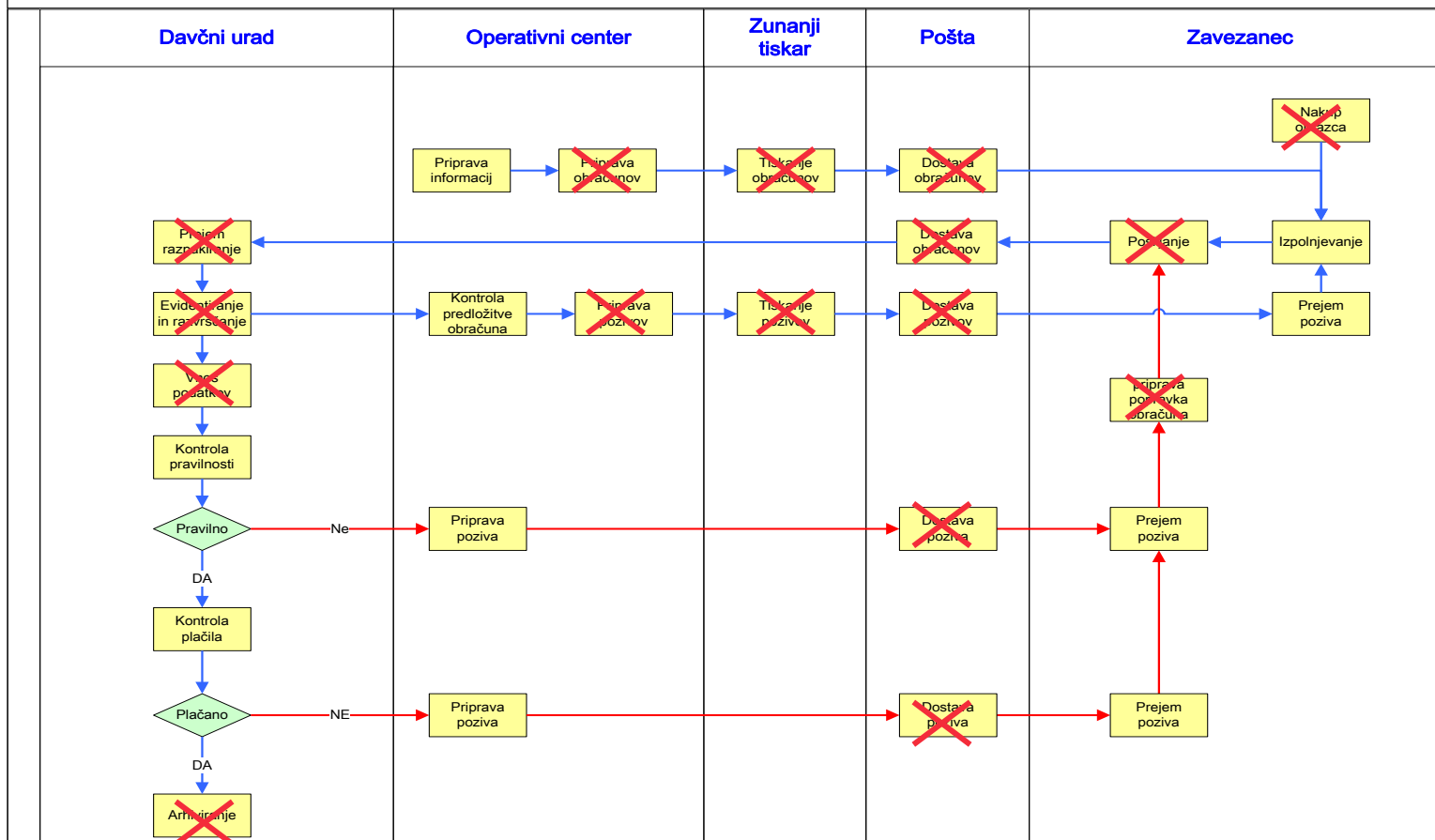

Prehod na ePoslovanje: za državljane

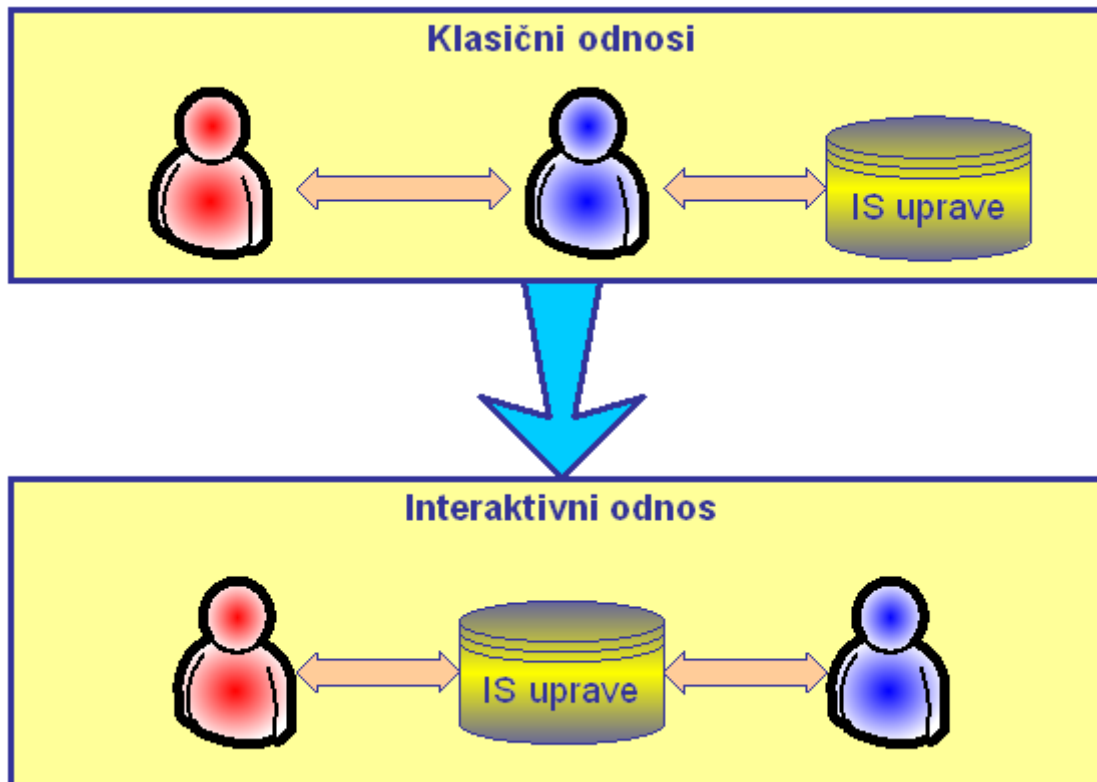

Prehod na ePoslovanje: za podjetja

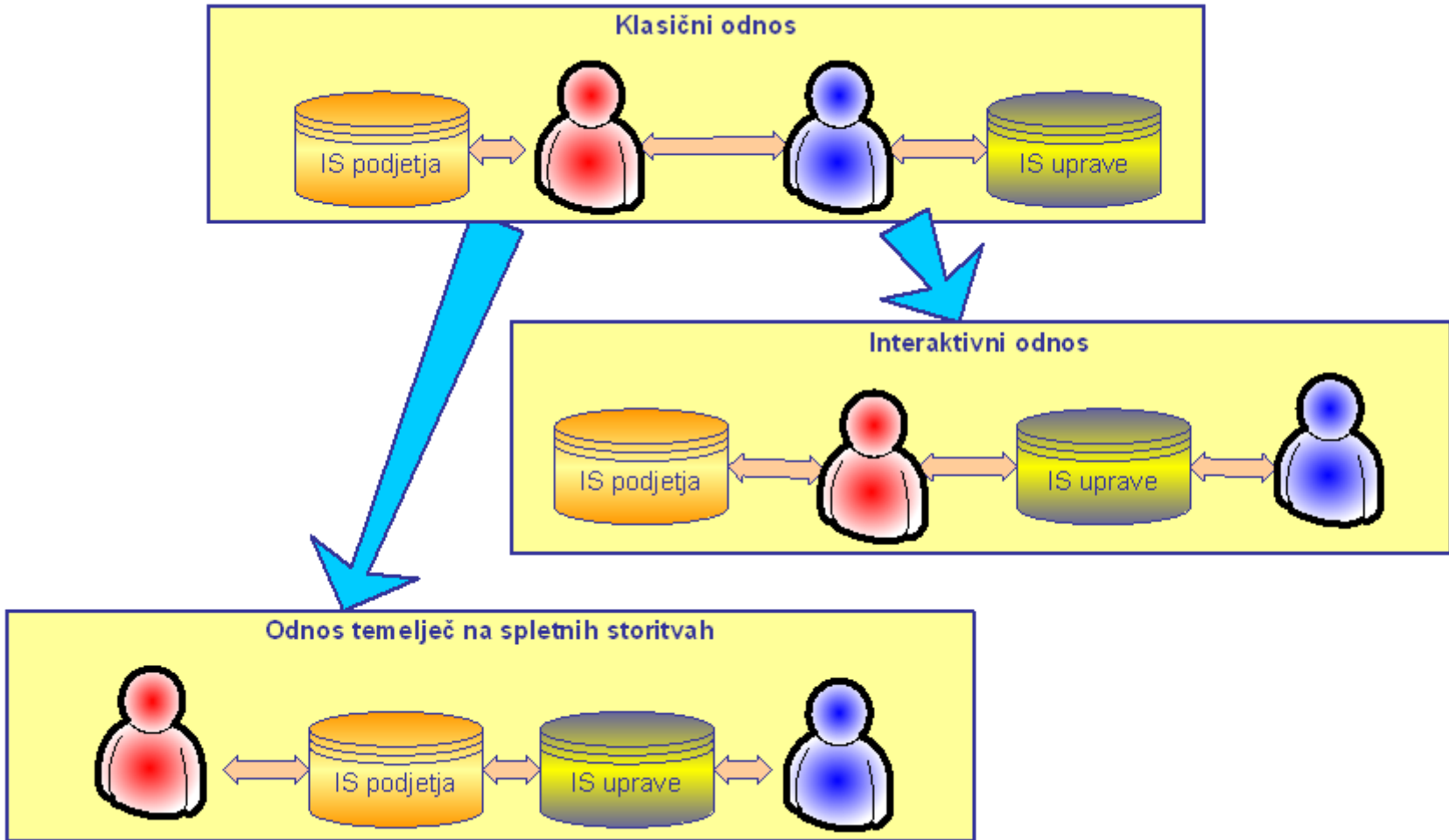

Obnašanje strank se spreminja

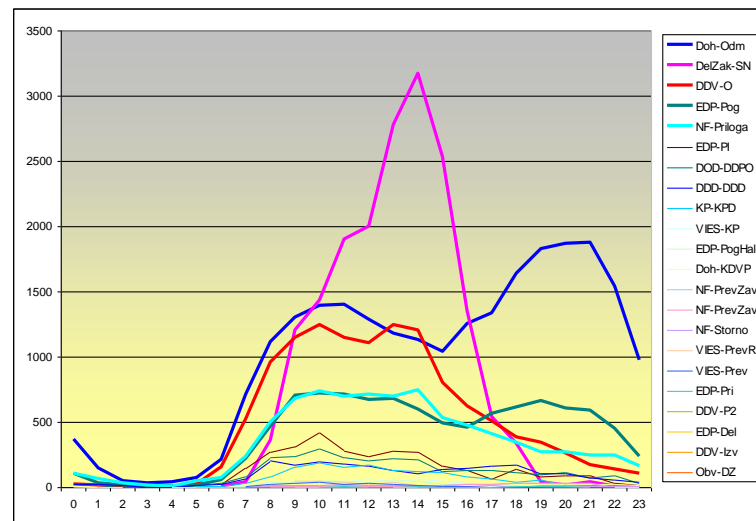
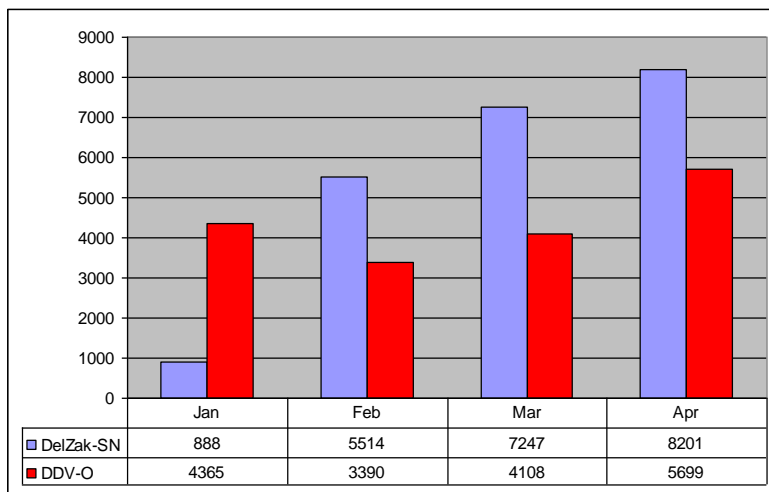
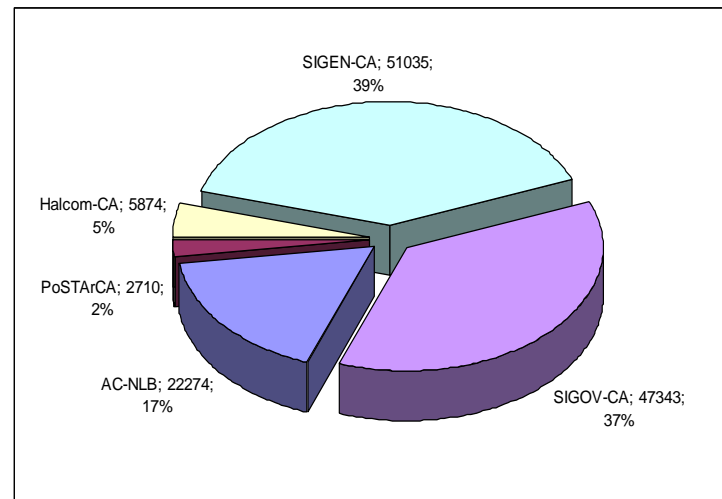
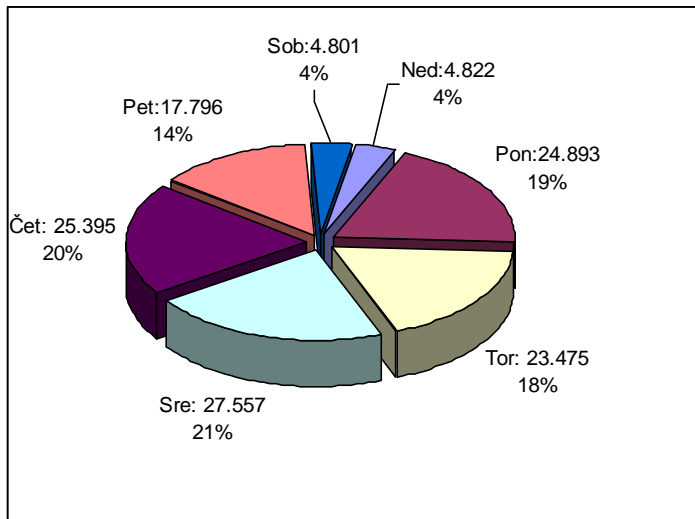

Primer eRašitve elektronsko davčno poslovanje



- ▶ **Enotno okno za poročanje**
- ▶ **Osnovne sestavine**
- ▶ **Uporabniki, uporabnost i uporaba**
- ▶ **eStoritve**
- ▶ **Sofisticirana varna rešitev**
- ▶ **Zakaj ni več uporabljena**

Enotno okno za poročanje

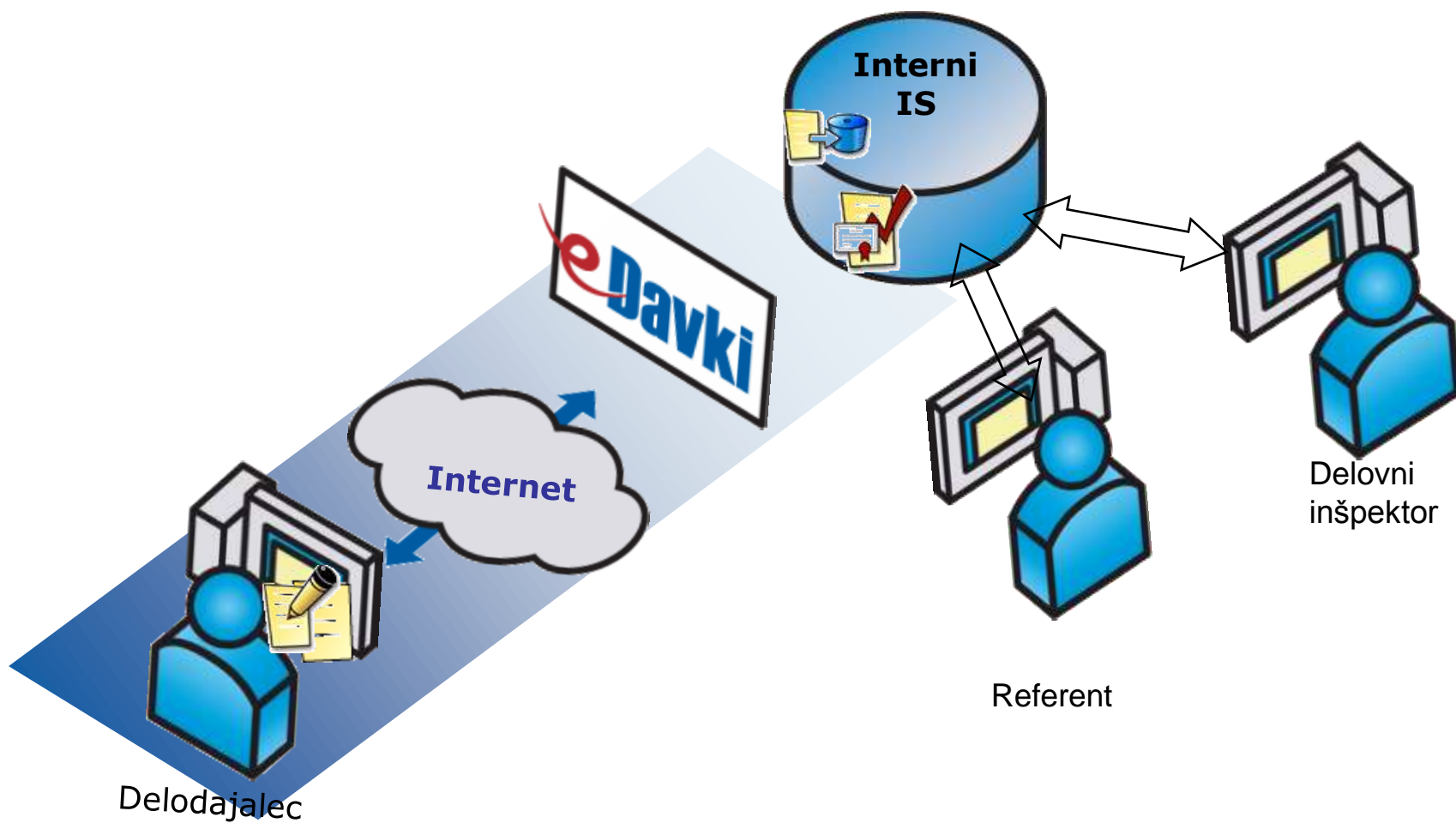

► **Rešitev aplikacije EDP je razgrajena po logičnih sklopih po tipu odjemalcev/uporabnikov:**

- Open Web Portal (Javni portal): splošni (javni) del EDP portala, dostopen vsem uporabnikom spleta
- Personal Web portal (Osebni Portal): varni del EDP portala, dostopen le z uporabo digitalnih potrdil
- Web services (SOAP API): varni del EDP portala (podobno kot Personal Web portal), le da gre tu za odjemalce spletnih storitev
- Custody Module (Skrbniški modul): varni del EDP portala, namenjen administratorjem sistema in skrbnikom

Personalizacija Za vse uporabnike

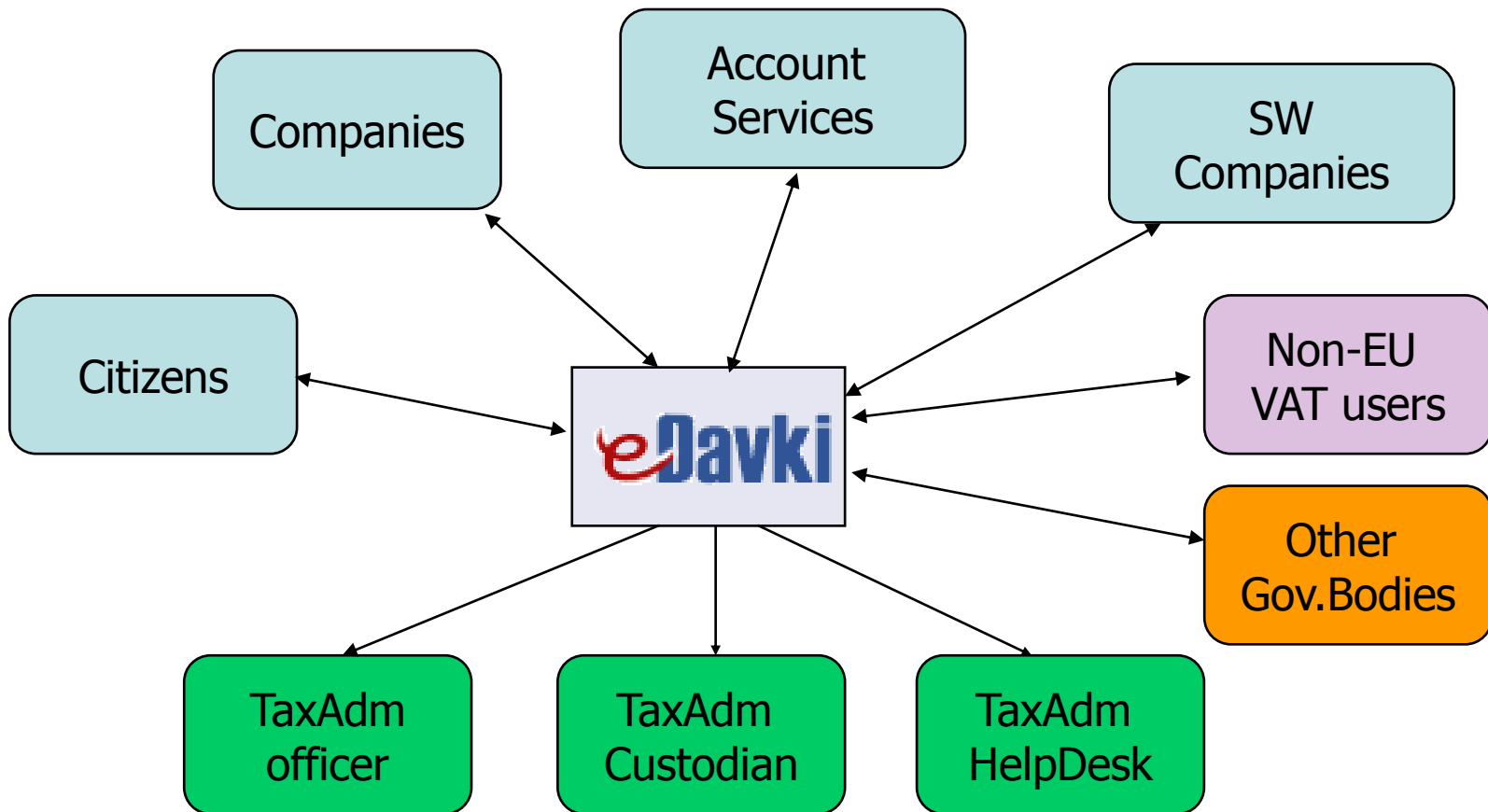

Za vse vrste digitalnih potrdil

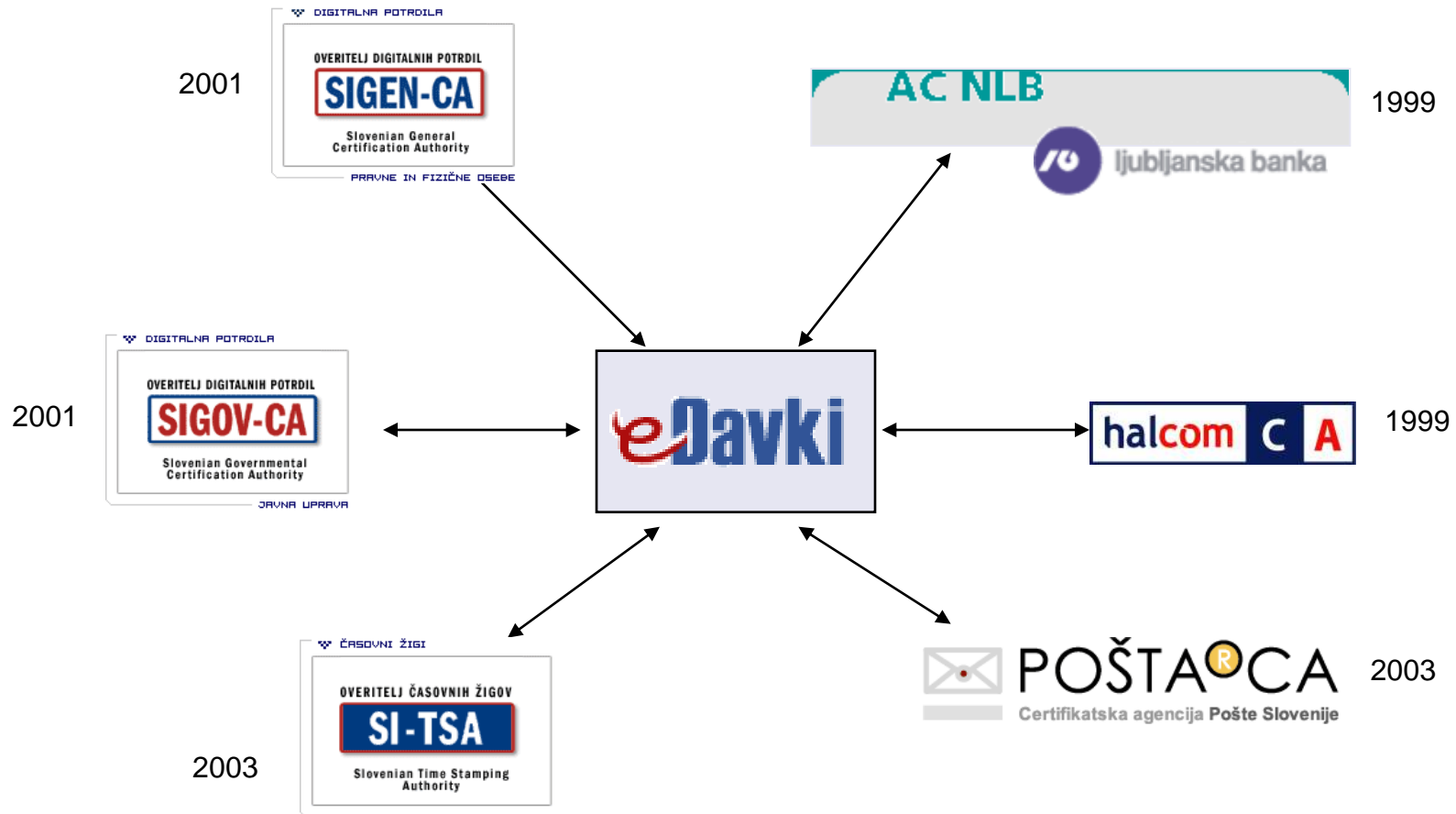

100.000+ digitalnih potrdil

Davčni obrazci



eDavki - Davčni obrazci v eDavkih - Windows Internet Explorer

http://www.ubp.gov.si/Operacija/Operacija.aspx?Forma=...

REPUBLIKA SLOVENIJA MINISTRSTVO ZA FINANCE - DAVČNA ORODJA 20

eDavki elektronsko davčno poslovanje

Vstop

Se želite registrirati?

Vladna stran

Predstavitev

Registracija

Wagejne dokumente

Posilščanje

Za razvijalce

Pravne podlage

Tehnična pomoč

Poslovni vprašanja

DDV za elektronsko upravljanje storitev

VAT in e-Services

Davčni obrazci v eDavkih

Elektronski davčni obrazci v eDavkih. Seznam je razdeljen na sklope po vrstah obrazcev.

Obrazec	Opis	FO	FOD	PO
Dohodnina				
Doh-Odm	Napoved za odmero dohodnine			●
Doh-KDVP	Napoved za odmero dohodnine od dobička iz kapitala od odsvojitve vrednostnih papirjev in drugih čezmejnih ter investicijskih kuponov	●		
Doh-DHO	Napoved za odmero dohodnine od obresti na dinamične depozite pri bankah in hranilnicah ustanovljenih v Sloveniji ter v drugih državah članicah EU			●
Obrazci DDV				
DDV-O	Obračun DDV	●	●	●
DDV-P2	Zahtevak za izdajo identifikacijske številke za DDV (domači)	●	●	●
DDV-Izv	Vloga za pridobitev statusa izvoznika	●	●	●
DDV-P3	Zahtevak za izdajo identifikacijske številke za DDV (tuji)	●	●	●
DDV-eRac	Prijava izdajanja in prejemanja računov v elektronski obliki	●	●	●
DDV-eRacPrek	Preklic prijaviteljeve izdajanja in prejemanja računov v elektronski obliki	●	●	●
Ostale vloge				
NF-PrevZav	Vloga za preverjanje podatkov o davčnih zavezancih	●	●	●
NF-PrevZavR	Poročilo o preverjanju podatkov o davčnih zavezancih	●	●	●
NF-LD	Lasni dokument	●	●	●
Splošni obrazci eDavkov				
EDP-Pog	Sprejem pogojev za uporabo portala	●	●	●
EDP-PI	Vloga za notranje posilščanje	●	●	●
EDP-PE	Vloga za zunanje posilščanje	●	●	●
EDP-Def	Vloga za brisanje profila uporabnika	●	●	●
EDP-PII	Obrazec za tignost osebnih podatkov	●	●	●
EDP-PogHil	Sprejem pogojev za preverjanje podatkov o imetniku digitalnega potrdila	●	●	●
EDP-Prisp	Prijava strožniškega potrdila za uporabo spletnih storitev	●	●	●
EDP-OrdSP	Odjava strožniškega potrdila za uporabo spletnih storitev	●	●	●
Obvestila				
Obv-DZ	Osebnostna obvestila	●	●	●
VIÉS				

eDavkih - Windows Internet Explorer

http://www.ubp.gov.si/Operacija/Pages/Introduction/IFerms.aspx

poln | poln

Obv v eDavkih

Obvestila				
Obv-DZ	Osebnostna obvestila	●	●	●
VIÉS				
VIÉS-Prev	Vloga za preverjanje identifikacijskih števk v EU	●	●	●
VIÉS-PravR	Poročilo o preverjanju identifikacijskih števk v EU	●	●	●
VIÉS-KP	Kvartalno poročilo	●	●	●
PODO – Prispevki in davčni odtegljaji				
REK-1	Obračun davčnih odtegljajev od dohodkov iz delovnega razmerja	●	●	●
REK-1a	Obračun davčnih odtegljajev od plačil vajencem, dijakom in študentom za obvezno praktično delo	●	●	●
REK-1b	Obračun davčnih odtegljajev od pokojnin, nadomestil in drugih dohodkov iz naslova obveznega socialnega zavarovanja	●	●	●
REK-1c	Obračun davčnih odtegljajev od pokojnin, nadomestil in drugih dohodkov iz naslova prostovoljnega pokojninskega in invalidskega zavarovanja	●	●	●
REK-1d	Obračun davčnih odtegljajev za dohodke iz drugega pogodbenega razmerja	●	●	●
REK-2	Obračun davčnih odtegljajev od dohodkov po ZDoh-2, ki niso dohodki iz delovnega razmerja	●	●	●
REK-2a	Obračun davčnih odtegljajev za dohodke iz dejavnosti	●	●	●
REK-2b	Obračun davčnih odtegljajev za druge dohodke iz osnovne kmetijske in osnovne gozdarske dejavnosti	●	●	●
REK-3a	Obračun davčnih odtegljajev za dohodke iz oddajanja premoženja in najem in za dohodke iz prenosa premoženjske pravice	●	●	●
REK-3b	Obračun davčnih odtegljajev za obresti in dividende	●	●	●
REK-4	Obračun davčnih odtegljajev za druge dohodke (98. člen ZDoh-1)	●	●	●
ODO-1	Obračun davčnih odtegljajev po 374. členu ZDovP-2 od plačil dohodkov rezidentov in nerazidentov po 70. členu ZDDPO-2 v povezavi z 266. členom ZDovP-2	●	●	●
Kontrolni podatki				
EP-KPD	Kontrolni podatki za dohodnino	●	●	●
Davek od dohodkov iz dejavnosti				
DDD-DDD	Napoved za odmero davka od dohodkov iz dejavnosti	●	●	●
Davek od dohodkov pravnih oseb				
DDO-DDPO	Obračun davka od dohodkov pravnih oseb	●	●	●
Dolovna zakonodaja				
DeZak-SH	Obvestilo o zaposlitvi dijakov ali študentov, ki so pričeli z delom na podlagi napotnic posilščanih organizacij	●	●	●
Obrestna direktiva ETI				
ODE-PDO	Poročilo o dohodku od prihrankov v obliki plačil obresti	●	●	●
Koncesijske dajatve				
KD-ODKD	Obračun dodatne koncesijske dajatve	●	●	●
Priloge				
NF-Priloga	Priloga	●	●	●

Postopek prve prijave



[eDavki.durs.si](http://edavki.durs.si)

Registracija

Naprej na Prvo prijavo

eDavki elektronsko davčno poslovanje

Vstop
Še niste registrirani?

Vstopite v eDavke

Registracija v eDavke
Za vstop v eDavke morate biti registrirani z digitalnim potrdilom.
[Kako se registriram?](#)

Vlaganje dokumentov
Prek eDavkov lahko svoje davčne obveznosti opravite hitreje in udobneje.
[Postopek oddaje](#)

Pooblaščenje
Pooblastite fizično osebo ali podjetje, da bosta lahko v

Prek eDavkov lahko vložite večino obrazcev, ki jih morate kot davčni zavezanci oddati DURS-u.
[Seznam obrazcev](#)

eDohodnina
Rok za oddajo: **31.3.2005**

Registrirani uporabniki
[Postopek oddaje](#)

Neregistrirani uporabniki
[Obrazec](#) (za vlogo po pošti ter informativni izračun)

Anketa
Kaj vas je prepričalo, da uporabljate eDavke?
 varnost
 enostavnost uporabe
 udobnost
 še ne uporabljam eDavkov
 eDavkov ne bom uporabljal

Splošna obvestila
[Arhiv obvestil](#)
1.4.2004
[Zahvala vsem uporabnikom e-dohodnine](#)
7.1.2005
[Pooblaščenje študentskih servisov](#)

DDV za elektronsko opravljene storitve

VAT on e-Services

Local intranet

Postopek prve prijave



Prva prijava

eDavki - Prva prijava - Microsoft Internet Explorer

File Edit View Favorites Tools Help

Address <http://edavki.durs.si/OpenPortal/Pages/Registration/RegistrationStart.aspx>

REPUBLICA SLOVENIJA MINISTRSTVO ZA FINANCE, DAVČNA UPRAVA RS

eDavki elektronsko davčno poslovanje

Vstop

Še niste registrirani?

- Vhodna stran
- Predstavitev
- Registracija
- Vlaganje dokumentov
- Pooblaščenje
- Za razvijalce
- Pravne podlage
- Pomoč
- Pogosta vprašanja
- DDV za elektronsko opravljene storitve
- VAT on e-Services

Vhodna stran ▶ Registracija ▶ **Prva prijava**

Prva prijava

Za prvo prijavo morate imeti nameščeno digitalno potrdilo. Kliknite Prva prijava za začetek postopka:

[→ Prva prijava](#)

Več o prvi prijavi

V postopku prve prijave boste namestili komponento za elektronsko podpisovanje in podpisali Pogoje za uporabo eDavkov. > [Poglej pogoje za uporabo](#)

Čas prenosa

Ob prijavi se bo na vaš računalnik naložila **komponenta za elektronsko podpisovanje** (kontrola ActiveX za Internet Explorer oz. Java za Mozilla).

Čas prenosa je odvisen od hitrosti vaše povezave z

Postopek prve prijave



Podpis - Microsoft Internet Explorer

Address: <https://edavki.durs.si/UserRegistration/CommonPages/Sign/IESign.aspx>

Links: Customize Links, Free Hotmail, Windows, Windows Marketplace, Windows Media

RS MF Davčna uprava RS

eDavki prijava uporabnika

Oddajanje vloge

S potrditvijo boste podpisali dokument in ga predložili davčni upravi. Vložena dokumenta ne morete več spreminjati.

Sistem: edavki.durs.si
Vložil: BORIS ZEBALC (20.03.2005 18:13:03)

Prijava uporabnika v sistemu eDavki

Uporabniški podatki za prijavo v sistem eDavke:

Davčni zavezanec: **BORIS ŽEBALC** DŠ:19295804 (Fizična oseba)

Pogoji in pravila uporabe

Uporaba teh spletnih strani oziroma informacijski sistem eDavki je pogojena s temi pogoji in pravili uporabe, vključno z uporabniškimi navodili (»Sprotna zaslonska pomoč« s pripadajočim »Slovvarjem izrazov«), kot tudi z veljavnimi predpisi Republike Slovenije na tem področju. S svojim pritiskom na gumb »Podpiši« na koncu besedila teh pogojev in pravil uporabe izrecno soglašate z njihovo vsebino in vstopate v pogodbeno razmerje z DURS ter potrjujete, da ste sposobni biti nosilec pravic in obveznosti iz tega pogodbenega razmerja.

DigSigX 1.1.1.19

Prepišite varnostno kodo s slike na levi:

Kontakt: edavki.durs@gov.si

eDavki je portal za elektronsko poslovanje z davčnimi dokumenti. Različica 1.7.24.1 [20.3.2005 18:19:07, 21]
© 2003-2005 **Davčna uprava RS**. Vse pravice pridržane.

Varnostna koda

Podpis

Postopek prve prijave



Podpisovanje dokumenta - Microsoft Internet Explorer

File Edit View Favorites Tools Help

Back Forward Stop Home Search Favorites Refresh Print Mail Stop

Address https://edavki.durs.si/UserRegistration/Pages/Documents/SignConfirmOK.aspx?id=EDP-19295804-38&form=EDP_Pog Go

Links Customize Links Free Hotmail Windows Windows Marketplace Windows Media

eDavki prijava uporabnika RS MF **Davčna uprava RS**

Uspešno ste se prijavi kot uporabnik sistema eDavki.

S podpisom dogovora ste se zavezali k spoštovanju poslovnih pravil o sodelovanju.

Vstop → Vstop v portal

Na javnih straneh eDavkov je gumb za vstop levo zgoraj.

Uporabniki eDavkov:

Vstop	eDavki elekt
DOMOV	Kliknite za vstop

Kontakt: edavki.durs@gov.si

eDavki je portal za elektronsko poslovanje z davčnimi dokumenti. Različica 1.7.24.1 [20.3.2005 18:28:15, 21]
© 2003-2005 **Davčna uprava RS**. Vse pravice pridržane.

Done Internet

Vstop

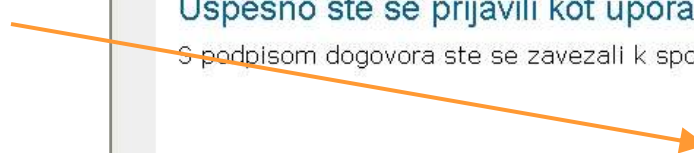

Prva stran

Davčni zavezanci

- Davčni zavezanci
- Omogočen dostop
- Onemogočen dostop

Dokumenti

Identifikacija uporabnika

Skrbniki

Pogosta vprašanja

Obvestila

Anketa

Evidence

eVAT

Dnevniki

Poročila

Šifranti

Parametri

Pomoč

✘ Izstop

Davčni zavezanci

Dostop do podatkov o davčnih zavezancih je omejen z vašimi pooblastili v sistemu eDavki.

Iskanje po davčni številkiDŠ: **Iskanje po ostalih podatkih**Naziv/Priimek Sedež/Ulica
Ime FO Kraj
Tip zavezanca PO FO SP

Kako e-Davki delujejo ?

Napoved za dohodnino

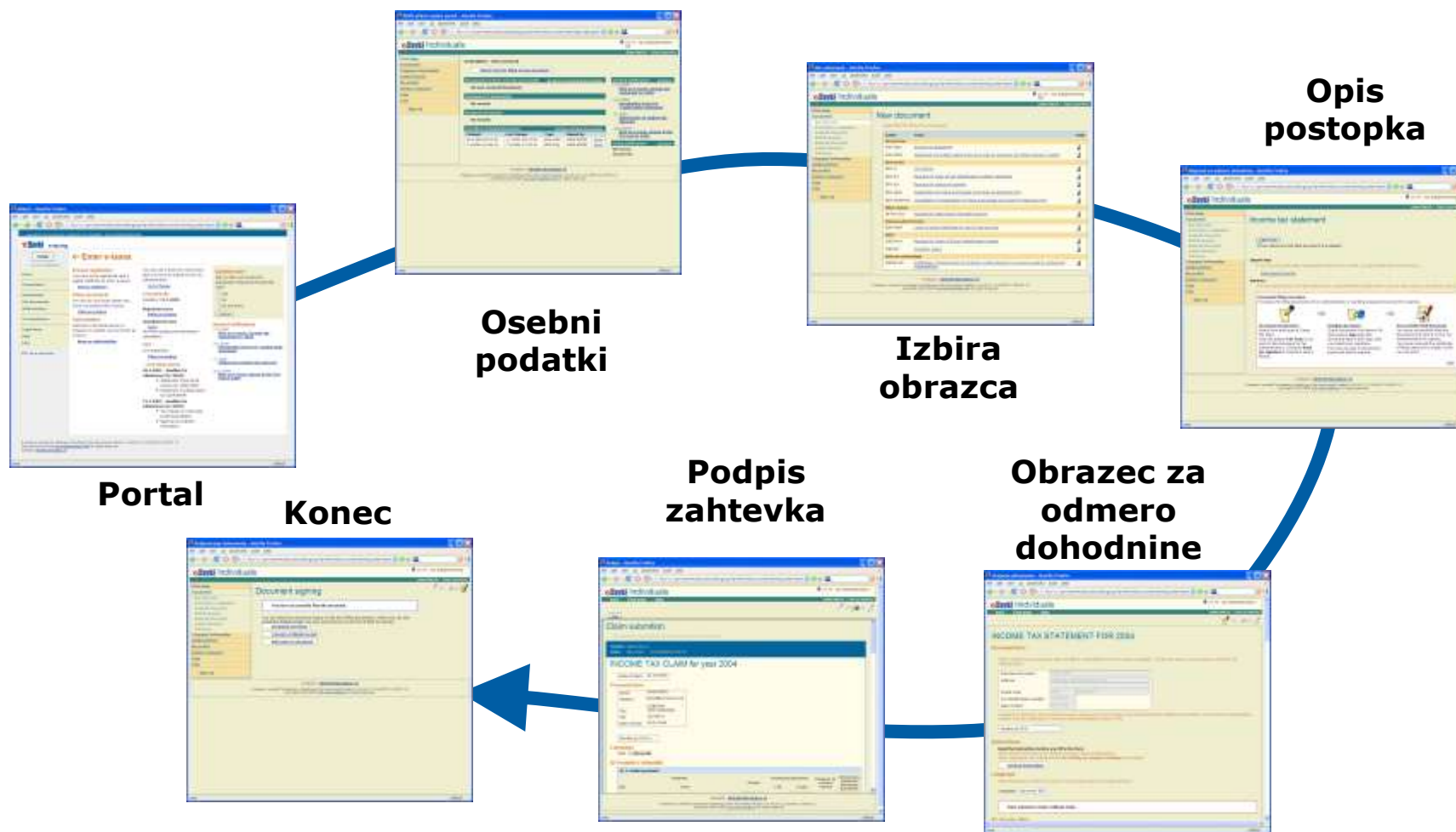

- Identifikacija uporabnika
- Identifikacija strežnika
- Zaščitena internetna povezava
- Preverjanje celovitosti podatkov
- Podpisovanje podatkov
- Časovni žig
- Neizpodbitnost dejanj
- Beleženje dogodkov
- Varnost strežnikov

Osebna odgovornost

- ▶ **Napredni IT standardi za G2G, G2B, G2C:**
 - XML 1.0
 - www.w3.org/TR/wds/
 - www.w3.org/TR/soap/
- ▶ **PKI**
 - XML Digitalno potrdilo (X.509v3)
- ▶ **Time stamping**
- ▶ **Večnivojske požarne pregrade**
- ▶ **SSL**
- ▶ **Pametne kartice, strojno šifriranje**
- ▶ **Protivirusna zaščita**
- ▶ **Zaščita proti avtomatskim Trojanskim konjem**
- ▶ **Sistem detekcije vsiljivcev**
- ▶ **Visoka razpoložljivost (99%)**

Infrastruktura javnih ključev (PKI)

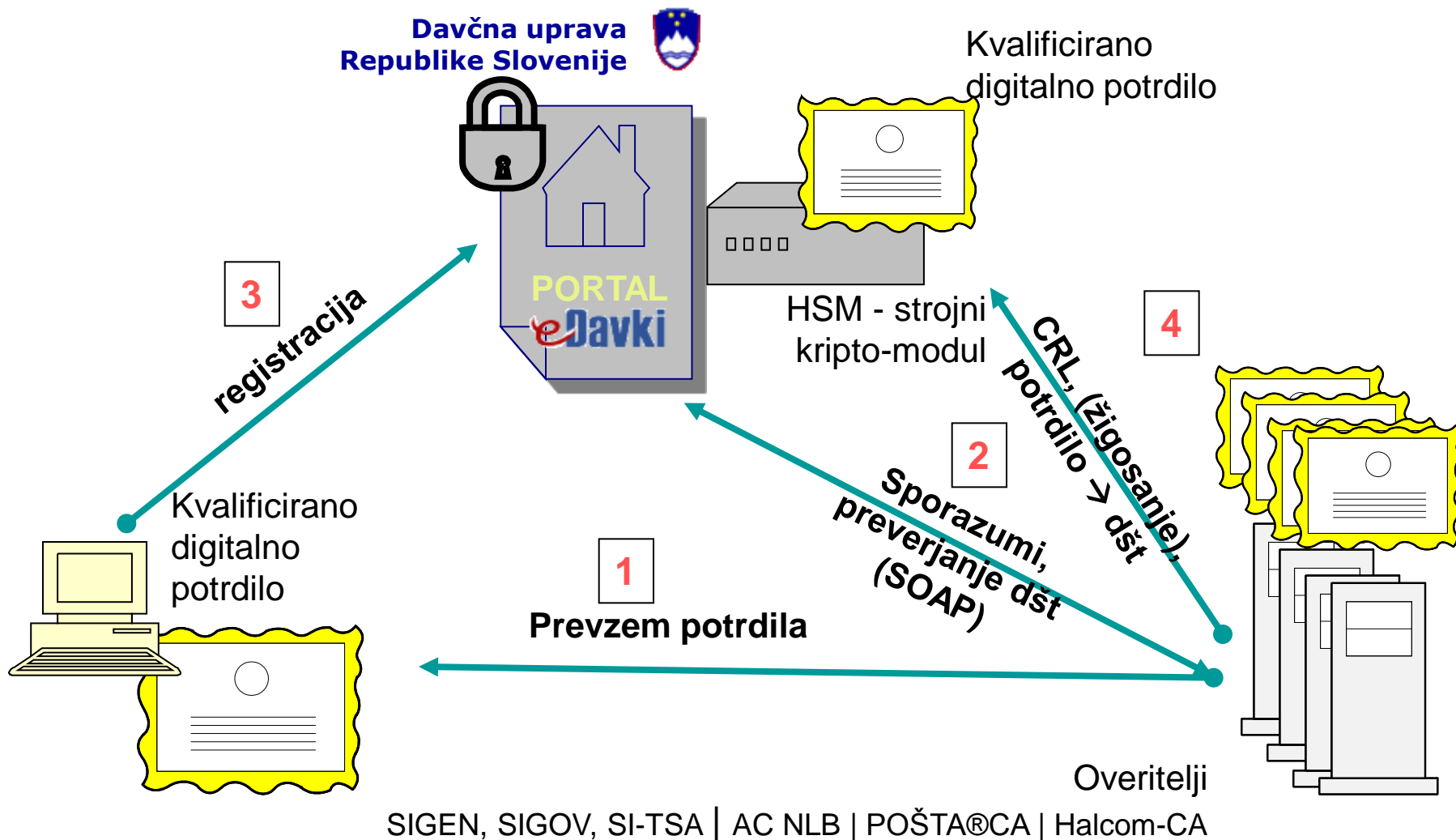

Podpisovanje in žigosanje

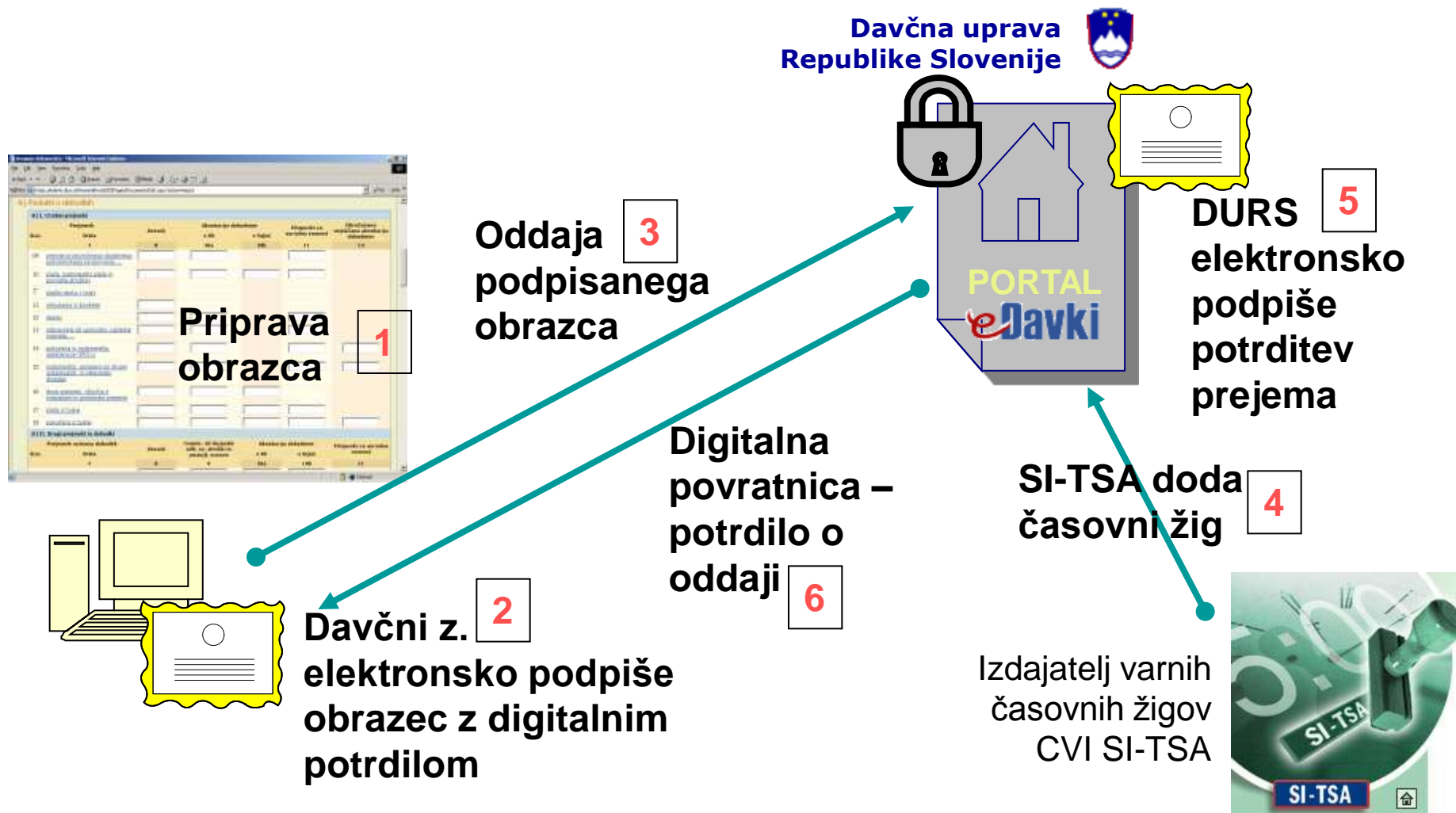

Tehnični pogled Podpisovanje eDokumenta

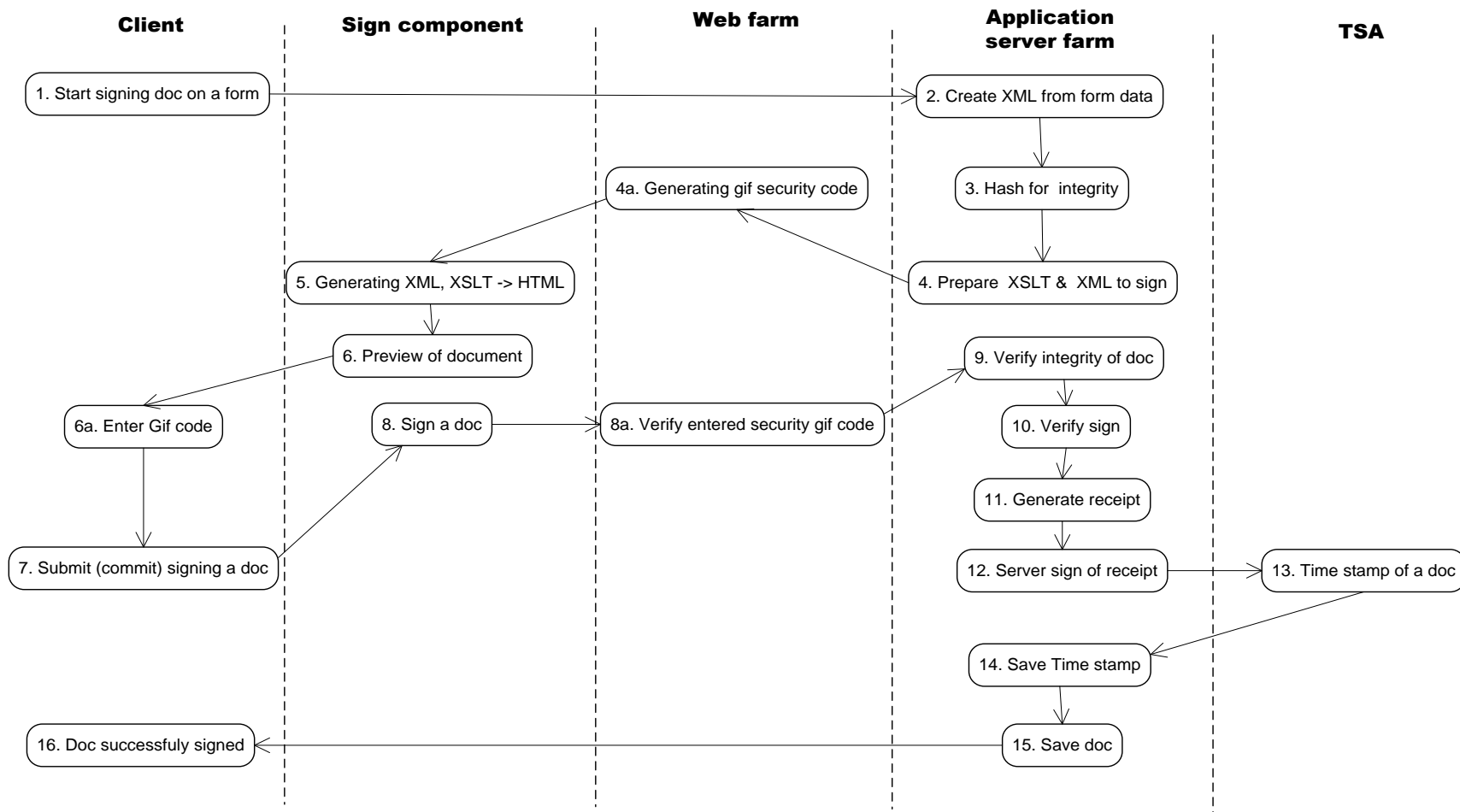

► Arhitecture...

- 3 tier
- MS .Net
- ActiveX and Applet on client (sign)
- .Net remoting between tiers
- Web & App Server Farms

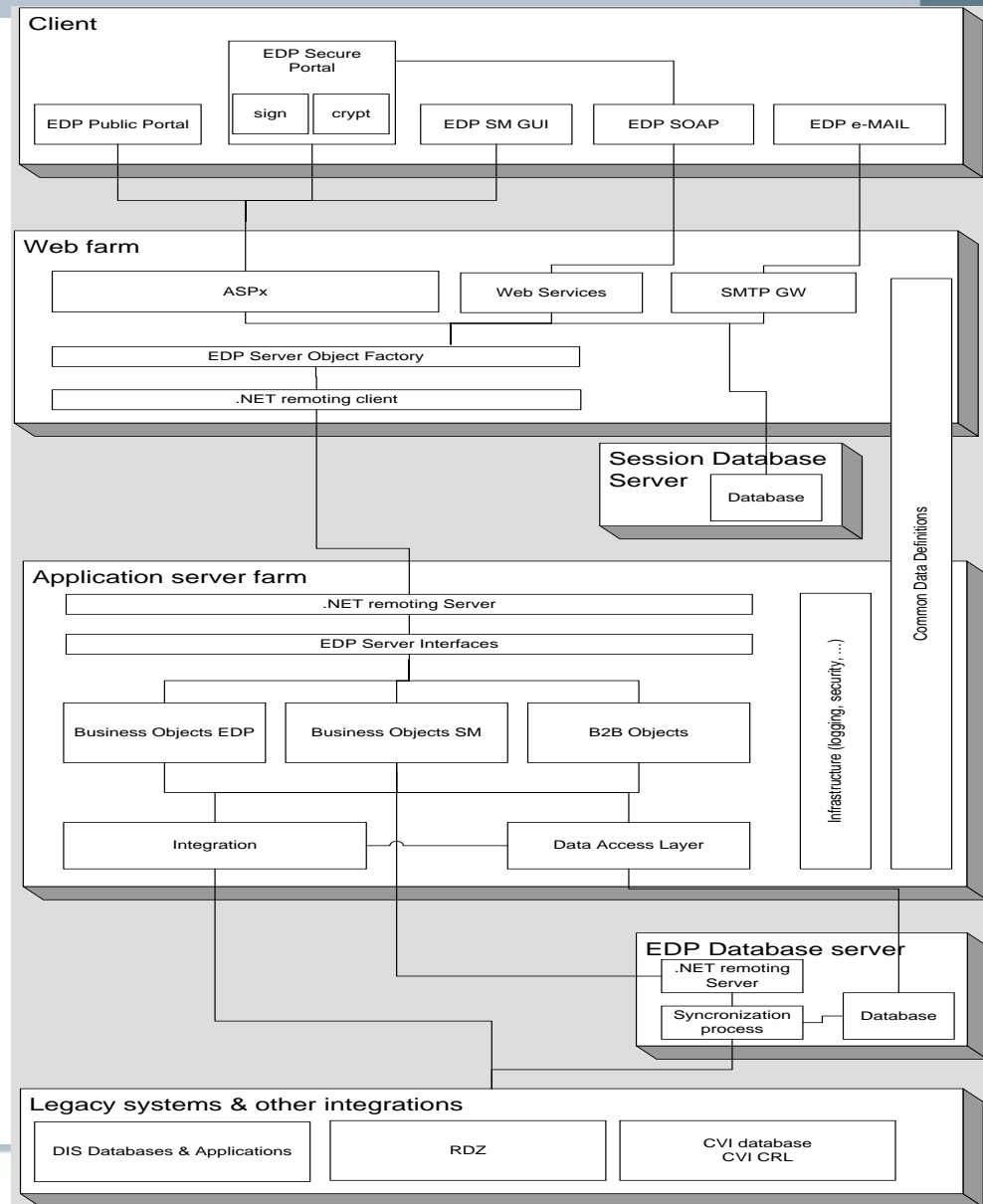



► Architecture

- Apache **"Trusted Gateway"**
 - HP-UX, IDS system
 - SSL session endpoint
 - Proxy for requests to Web farm
- Clustering **Services**
- IIS 6.0
- **MS SQL Server 2000**
- **MS ASP.NET**
- **MS Windows Server 2003**
- **MS BizTalk Server 2004**
 - Integration to BackOffice
- Yukon (beta)
 - Replication BackOffice
 - Oracle 2 MS SQL
- Network Load balancing

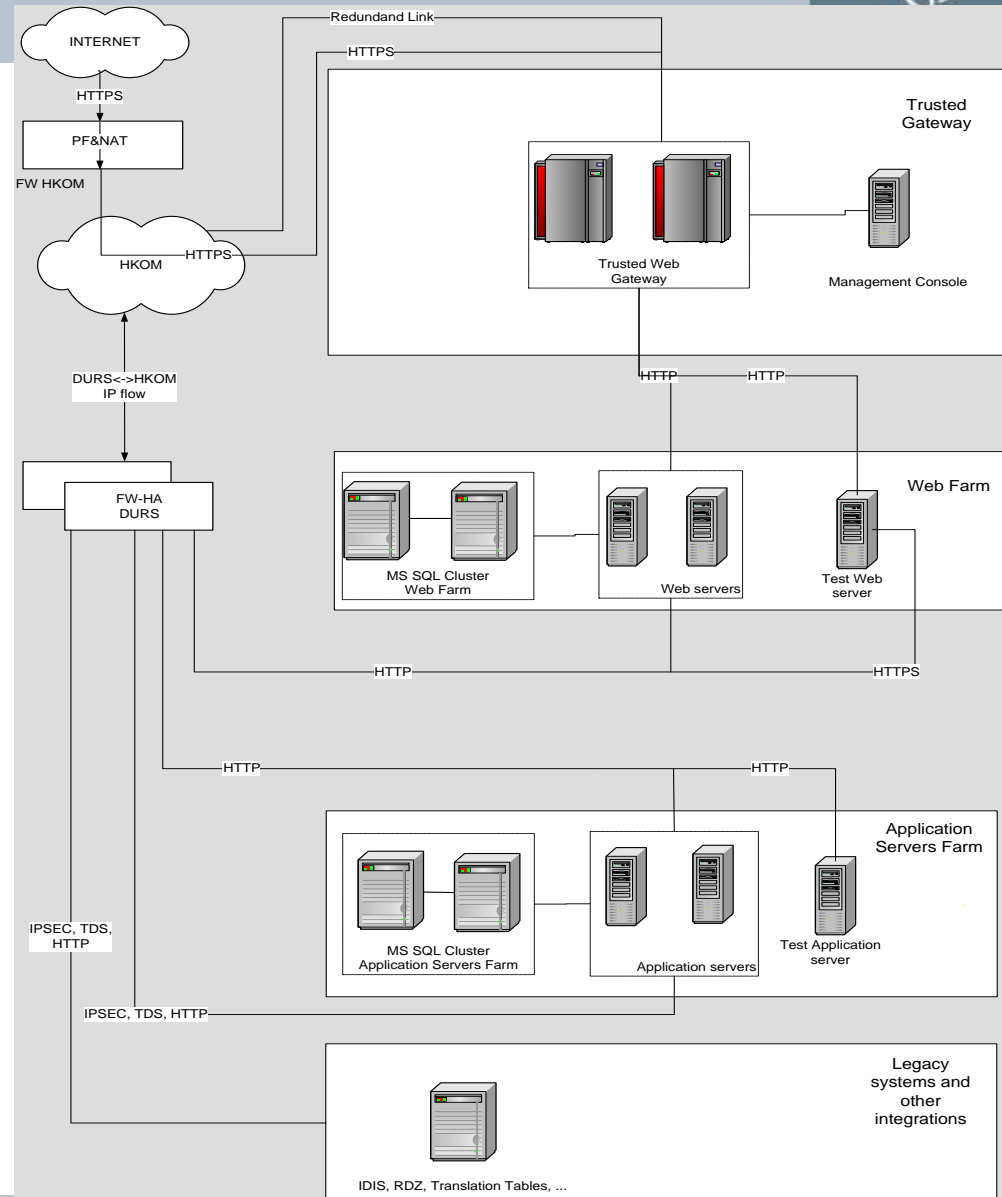

Statistika

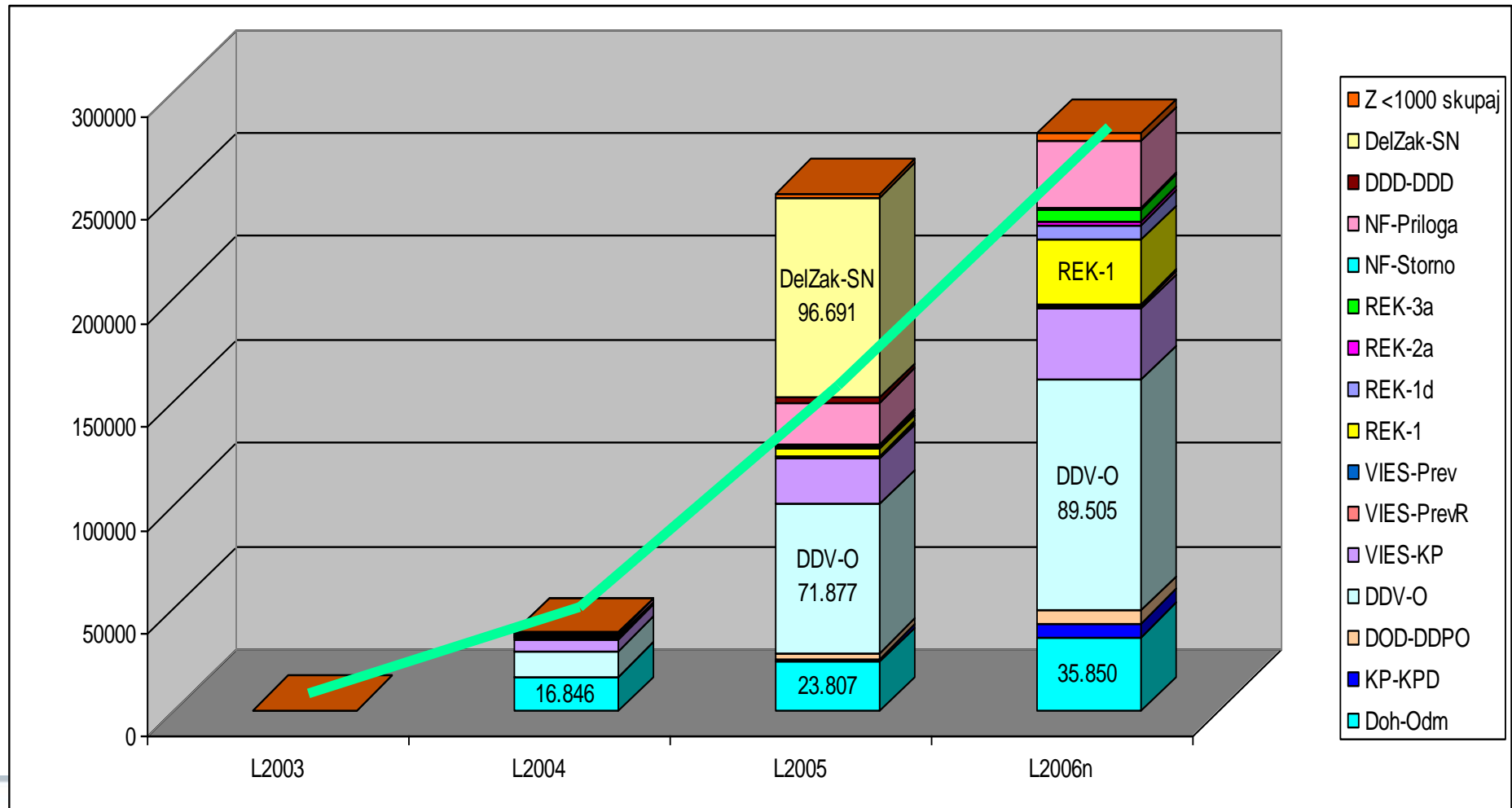

- Z <1000 skupaj
- DelZak-SN
- DDD-DDD
- NF-Priloga
- NF-Storno
- REK-3a
- REK-2a
- REK-1d
- REK-1
- VIES-Prev
- VIES-PrevR
- VIES-KP
- DDV-O
- DOD-DDPO
- KP-KPD
- Doh-Odm

Statistika e&p vlaganje dokumentov

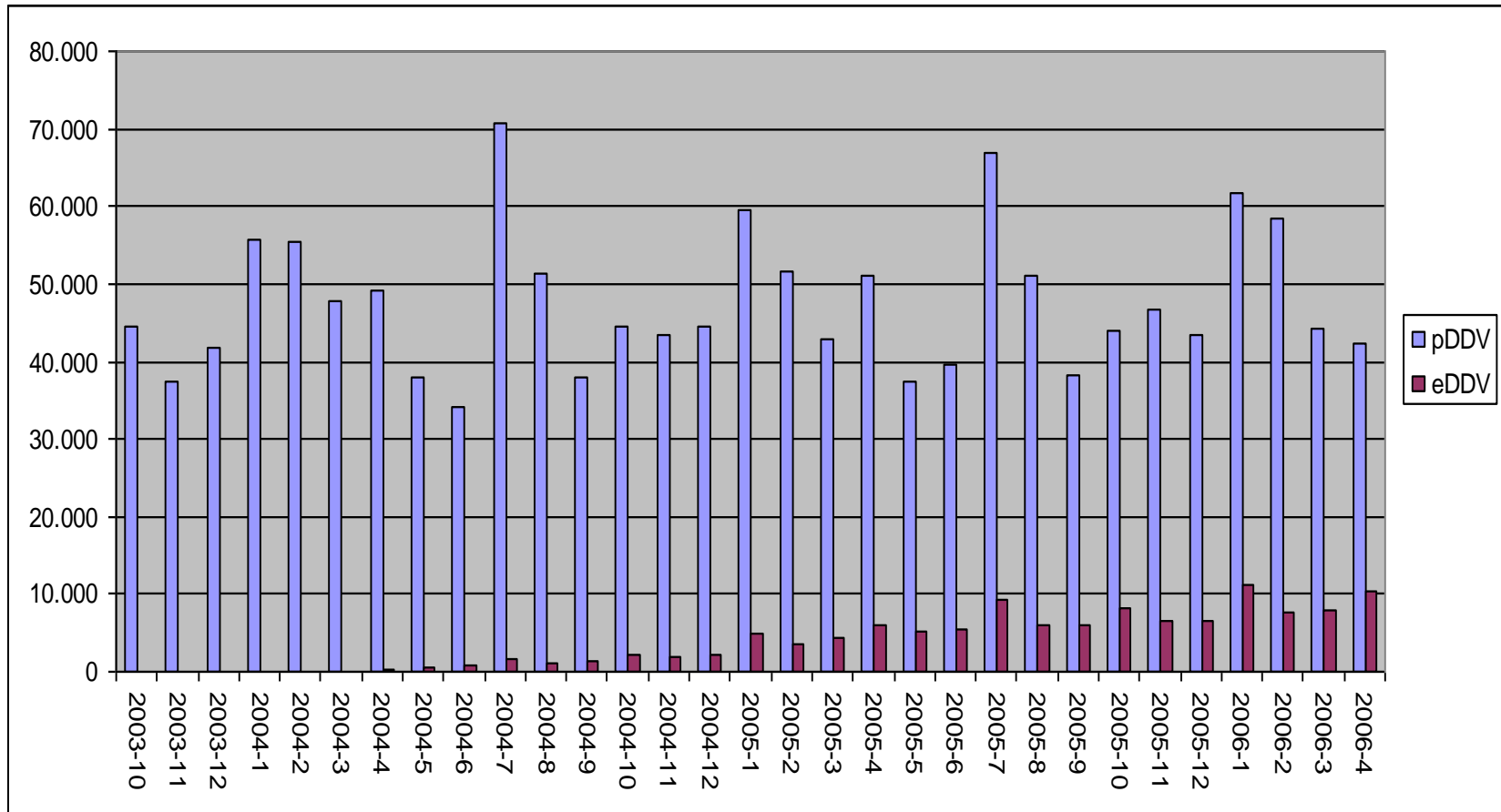

Statistika 2006 vlaženi dokumenti

Oddanih v 2006

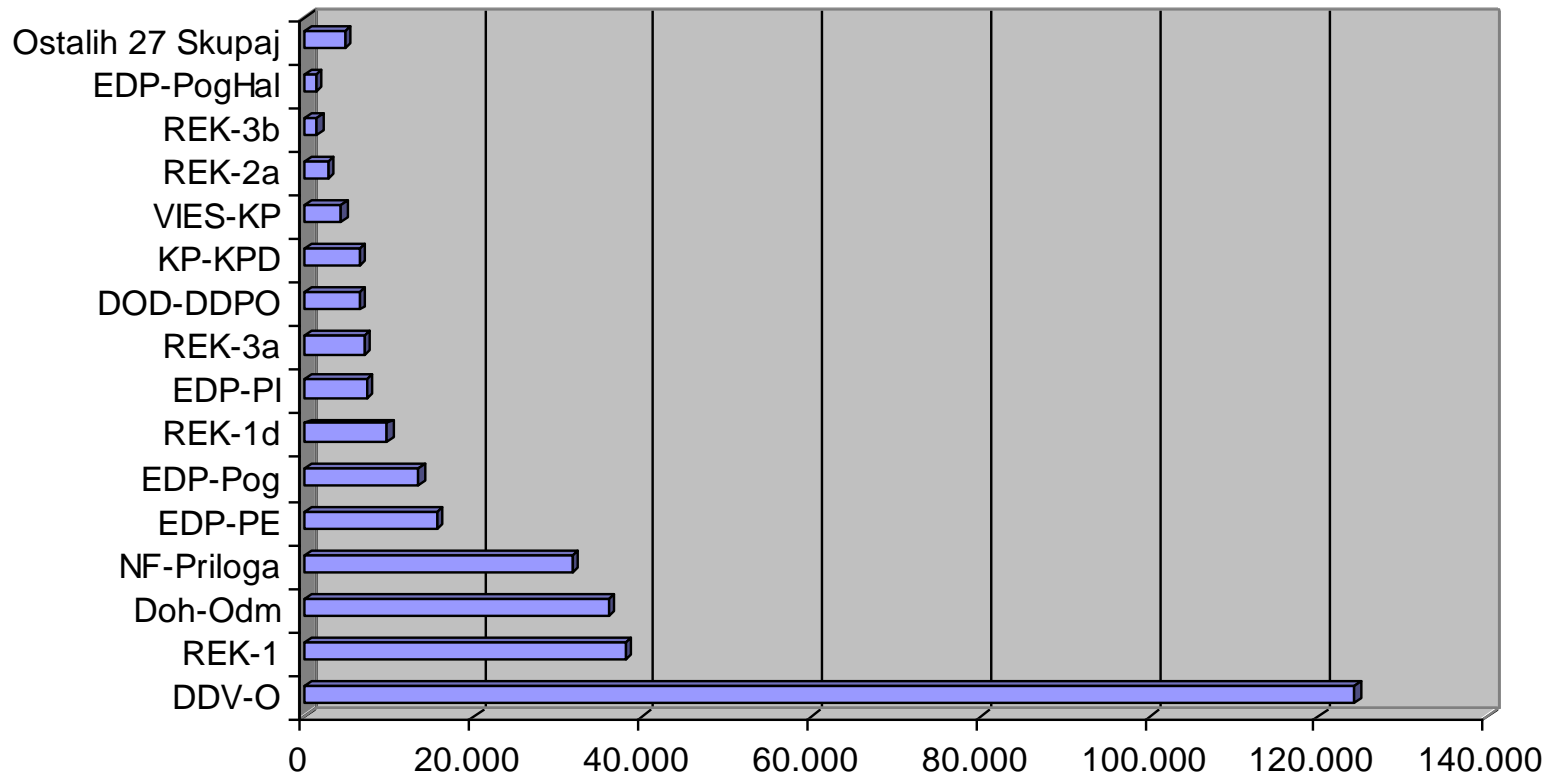

- ▶ **The European Commission in co-operation with the Member States has finalised the roadmaps for the action plans on Pan-European Electronic Identity Management, Electronic Procurement and Inclusive eGovernment.**
- ▶ **In view of the continuous and fast evolution in these areas, we shall conduct an annual revision of these roadmaps.**
 - **Electronic Identity Management**
 - **Electronic Procurement**
 - **Inclusive eGovernment**



General

- **New strategy of eGovernment from 2006 until 2010** adopted Strategy in April 2006. The strategy takes into account modern guidelines and initiatives which have been passed at EU ("i2010 – A European Information Society for Growth and Employment" and the Manchester Ministerial Declaration). Link: http://www.mju.gov.si/en/legislation/important_documents/.
- **Action Plan of e-government:** in preparation (being drafted).
- **Documentary and Archives Material Management and Archives Act:** Recently adopted. All electronic records (including digitised documents) shall have full legal effects. The new act also regulates registration and accreditation of equipment and service providers: Link: <http://www.arhiv.gov.si/fileadmin/arhiv.gov.si/pageuploads/zakonodaja/ZVDAGAA.pdf>.

Inclusive eGovernment

- **Cultural diversity:** Within the Riga declaration Slovenia is a promoter of cultural diversity. Slovenian activities: digitalisation, the creation of accessible digital content, and wide access to digital information and cultural heritage of museums, libraries, audio/video archives.
- **Action Plan of e-Accessibility:** in preparation (being drafted)

Efficient & Effective Government

- **Removing administrative burden:** The government has adopted the Programme of Measures for Reduction of Administrative Burdens, which contains concrete measures aimed at simplifying procedures and raising the quality of administrative services. Interested stake-holders are invited to cooperate in decision-making regarding the elimination of administrative obstacles. Link: http://www.mju.gov.si/en/aktualno/methodology_and_oao/
- **Measurement of customer satisfaction** based on the CAF model.



High Impact Services

- **One stop go (OSG) for entrepreneurs:** The portal since July 2005: to provide user-friendly, simple, attainable and safe services, which can be access via internet anytime and anyplace. It enables the entrepreneurs to register in Business Register and forward the information to the Tax Administration, apply for himself/herself and other family members for compulsory health insurance at the Health Insurance Institute of Slovenia, change data or delete one's own activity or request information about another sole trader. The portal will be expanded to other types of companies until the July 2007. Link: <http://evem.gov.si/sp/>
- **Modernised portal e-government:** went live on 22 May 2006. It is an access point to public administration information and services, which lists information in groups of 'life events'. The portal provides easy access to information offered by the state and user-friendly use of services, which the citizen needs when dealing with the state. The modernised portal includes a more comprehensive list of civil servants to whom a citizen can submit an application and enables the citizen to communicate with public administration bodies, which ensures a quick response and user-friendly information. The newest electronic service: Renewing a driving licence on-line. Link: <http://e-uprava.gov.si/e-uprava/>
- **Slovenian eTax system:** a complete business solution combining a web portal with back office integration and the highest level of security based on a PKI infrastructure. It connects with other government institutions and includes information exchange as required by EU regulations, in particular the E-Commerce Directive. Link: <http://eDavki.durs.si>

Key enablers

- **Electronic Communication and Electronic Signature Act** adopted in September 2000.
- **Governmental Certification Authority SIGEN-CA** issues qualified certificates to citizens and private sector, operational since 2001. Until now: 53.000 issued certificates. Link: <http://www.siggen-ca.si/>

- ▶ Poslovni subjekti (podjetja in posamezniki) redno poročajo podobne ali enake (iste) podatke na več javnih organizacij/inštitucij (DURS, AJPES, ZPIZ, ZZZS, ZRSZ, SURS, MDDSZ...)
- ▶ Poleg tega podjetja iz nekaterih panog poročajo še drugim državnim organizacijam.

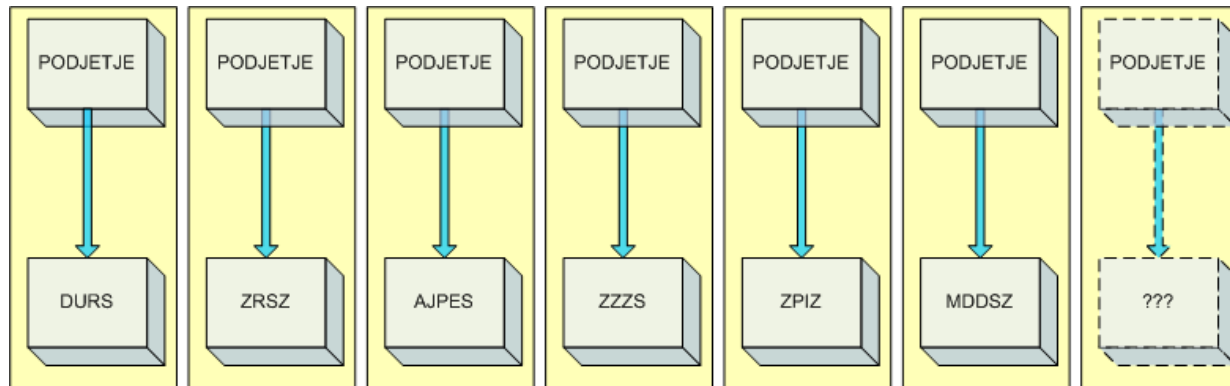

▶ Kaj so ključni problemi pri tem:

- Večkratno poročanje in celo zagotavljanje podatkov, ki so že na voljo v upravi
- Zaradi časovnih zamikov pri poročanju se podatki med seboj razlikujejo
- Podatki se podvajajo – nikjer ni ažurnega referenčnega stanja
- Prejemniki podatkov prejete podatke dodatno medsebojno izmenjujejo
- Poročanje poteka večinoma papirno, čeprav so vsi podatki pri podjetjih že v nekem internem informacijskem sistemu

Kako bi jo lahko rešila eUprava

Enotni državni portal

► Predlog:

- Uvesti enkratno poročanje državi, ki naj si podatke interno deli
- Zmanjšati število točk za korespondenco (poročanje in informiranje) - SEW
- Podatke zbrati le enkrat in uporabiti večkrat

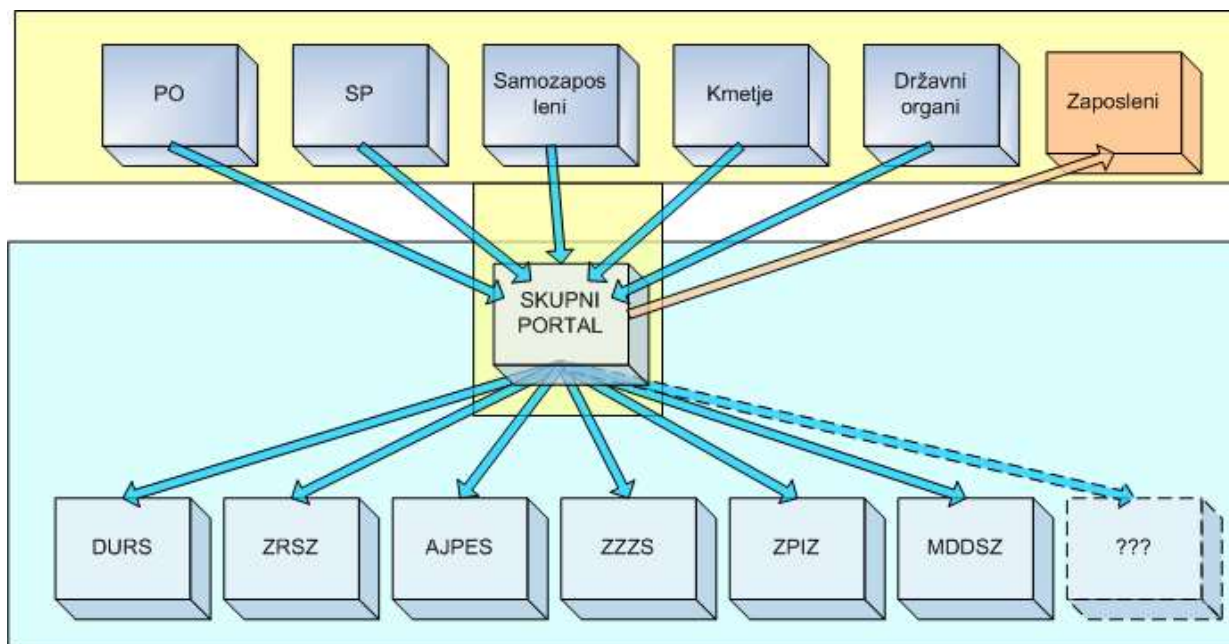

- Omogočiti osebni nadzor

- ▶ **Davki - eTaxes**
- ▶ **Zdravstvo – eHealth**
 - Kartica zdravstvenega zavarovanja
- ▶ **Registracija poslovnih subjektov**
 - eVEM
- ▶ **ePoslovanje**
 - Javne nabave
 - Računi
- ▶ **Elektronske identifikacije**
 - Osebna izkaznica
 - Biometrični potni listi

Kaj eUprava je/ni!



- ▶ Uradne ure ob sobotah?
- ▶ Na dom dostavljena napoved za dohodnino?
- ▶ VIDA – davčna asistentka?
- ▶ Podaljšanje prometnega dovoljenja tako kot je zdaj?
- ▶ Registracija podjetnika v nekaj dneh?

Online availability of Public Service: How is Europe Progressing?

**Web Based Survey on Electronic Public Services
Report of the 6th Measurement
June 2006**

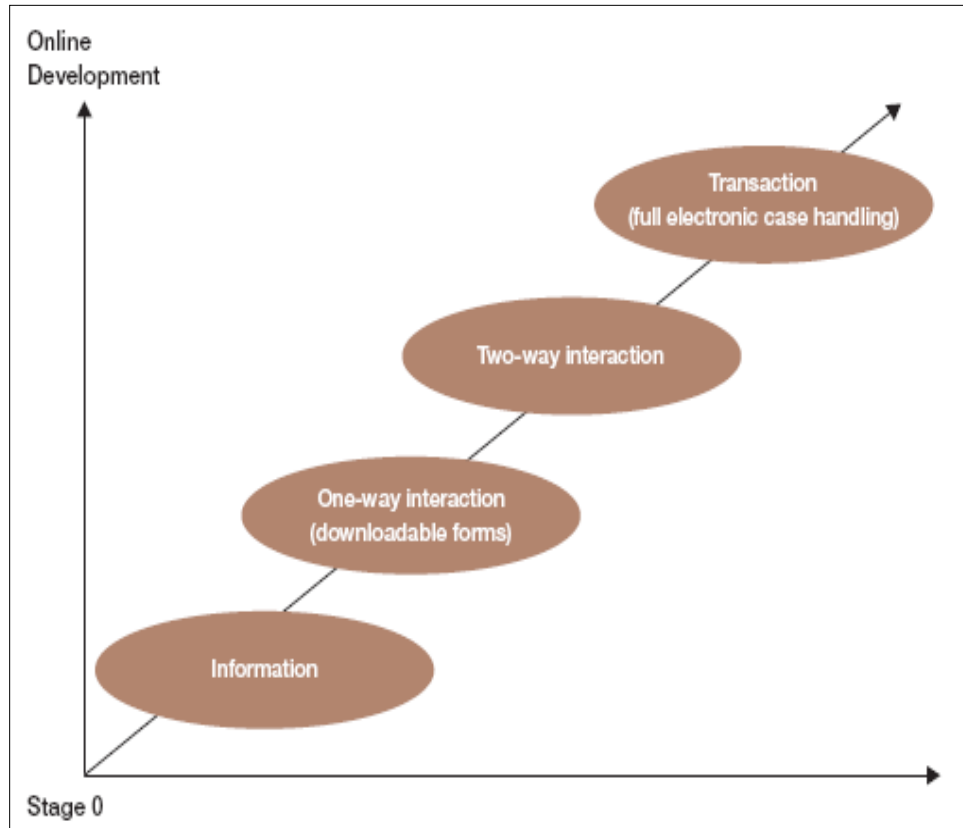

Citizens	Businesses
Income Taxes	Social Contribution for Employees
Job Search	Corporate Tax
Social Security Benefits ³	VAT
Personal Documents ⁴	Registration of a New Company
Car Registration	Submission of Data to the Statistical Office
Application for Building Permission	Custom Declaration
Declaration to the Police	Environment-related Permits
Public Libraries	Public Procurement
Birth and Marriage Certificates	
Enrollment in Higher Education	
Announcement of Moving	
Health-related Service	

Online availability of Public Service: How is Europe Progressing?



Web Based Survey on Electronic Public Services
Report of the 6th Measurement
June 2006

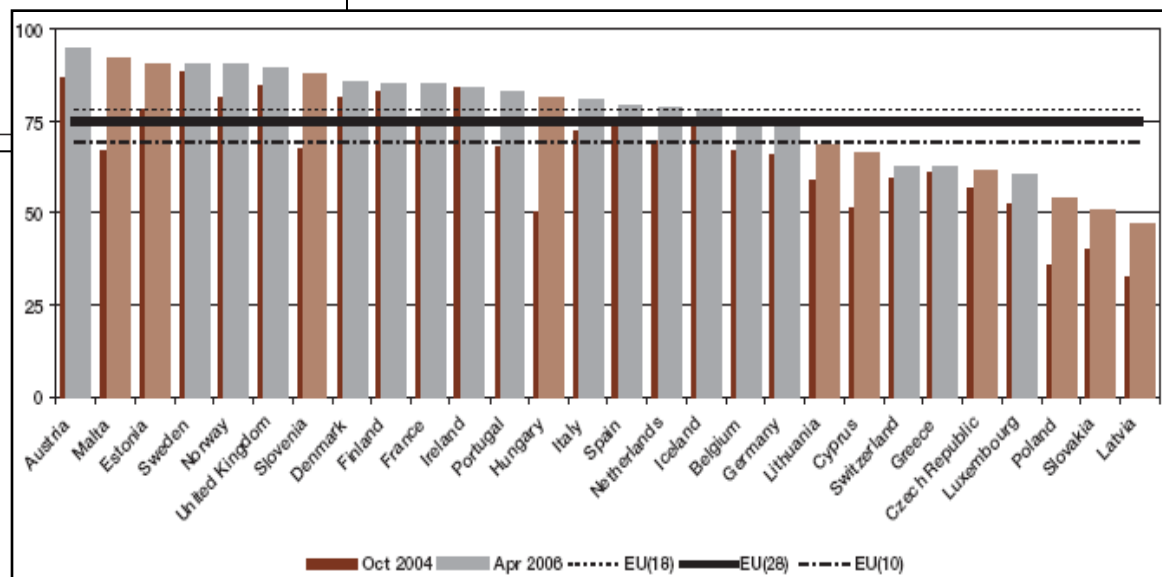
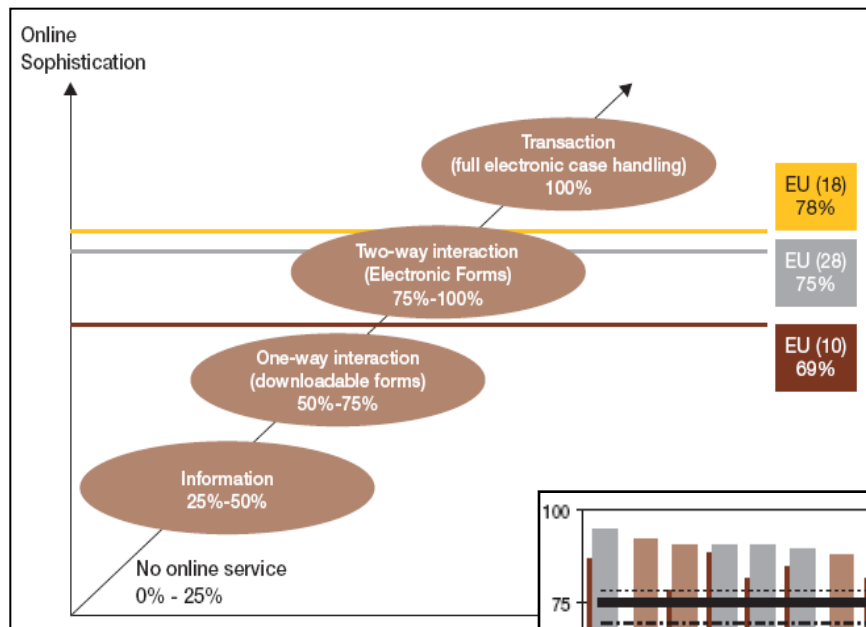

eServices for Businesses

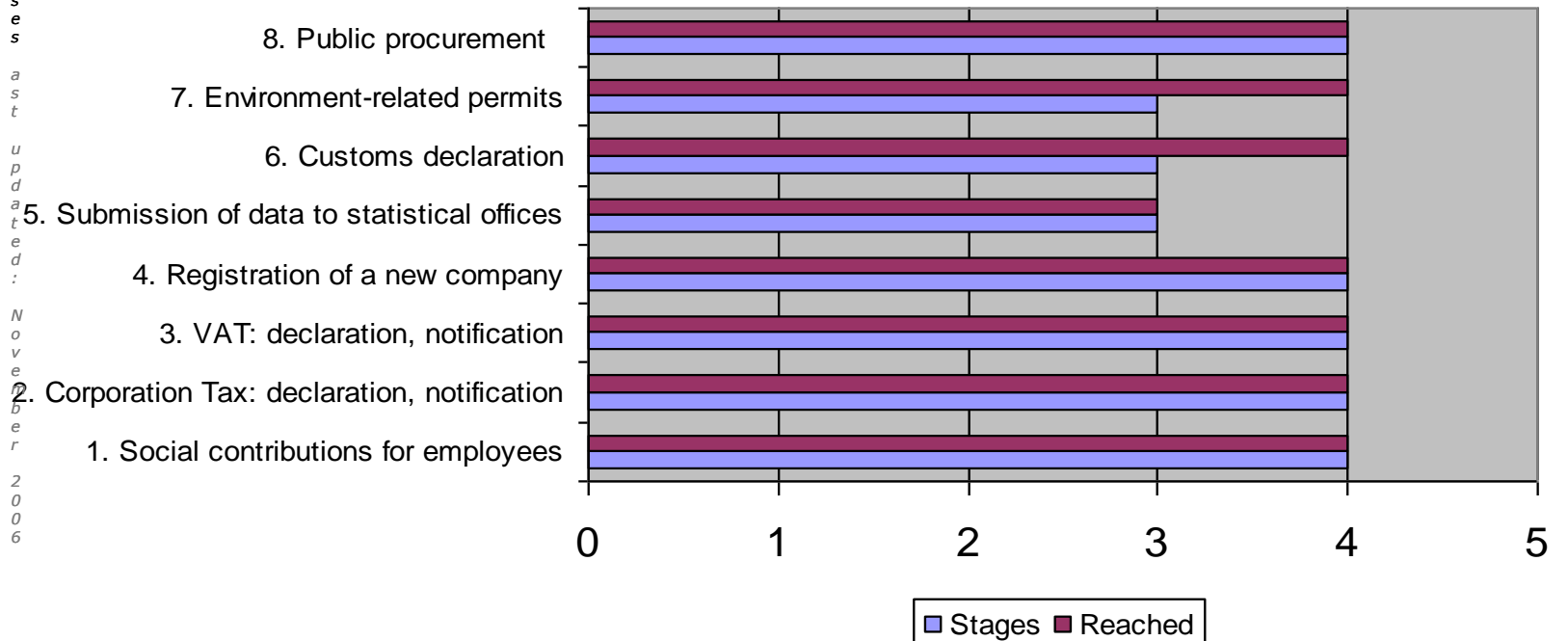

eGovernment Factsheet - Slovenia - eServices for Businesses

Availability and sophistication of eServices for Businesses;

Last updated: November 2006

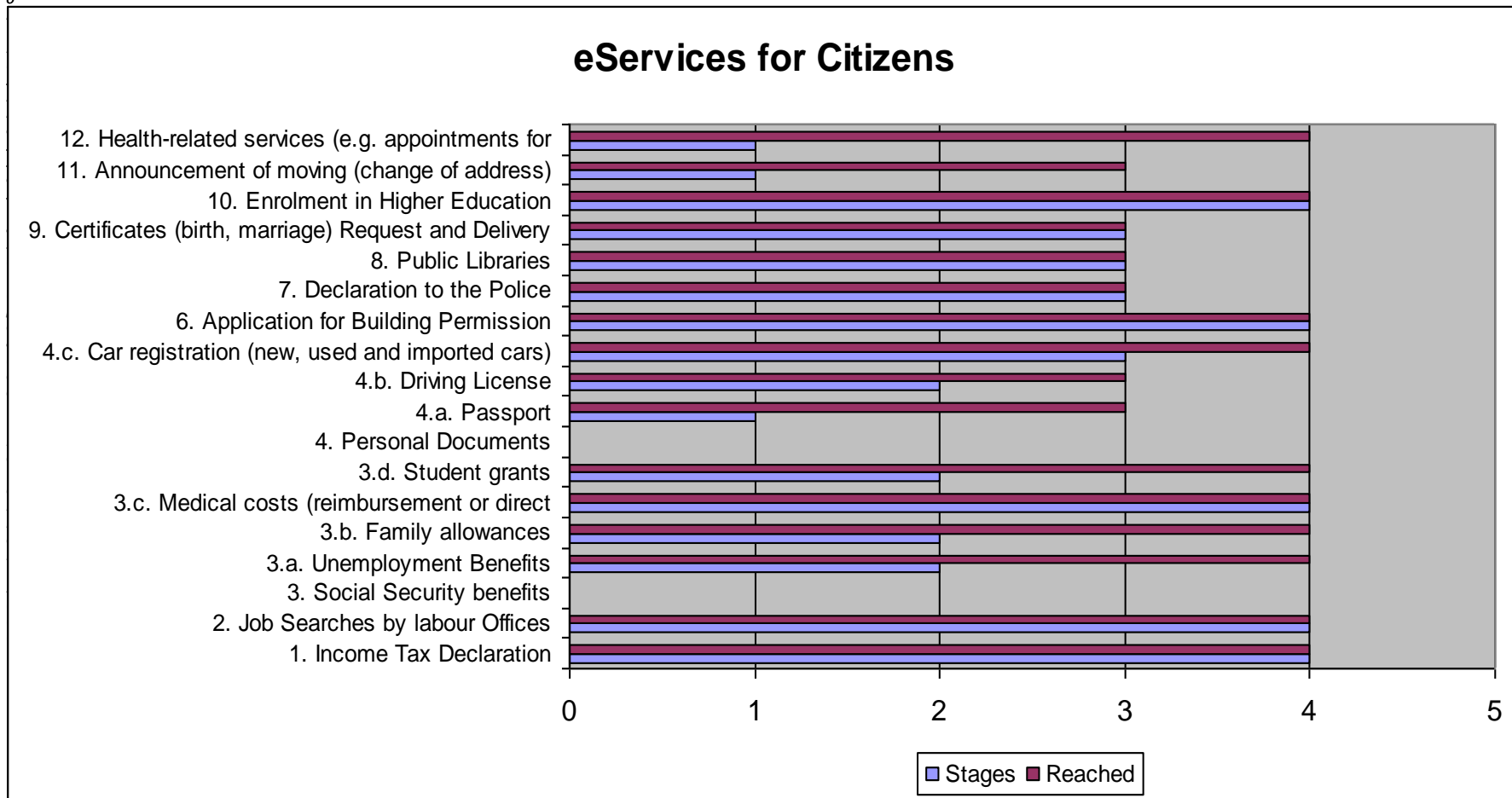

eGovernment Factsheet - Slovenia - eServices for Citizens

Availability and sophistication of eServices for Citizens;

Last updated: November 2006

Online availability of Public Service: How is Europe Progressing?

**Web Based Survey on Electronic Public Services
Report of the 6th Measurement
June 2006**

Figure 14: Registration Services

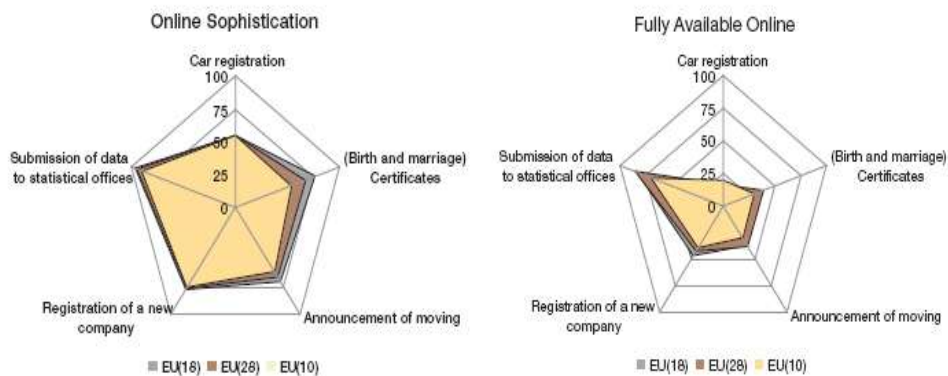
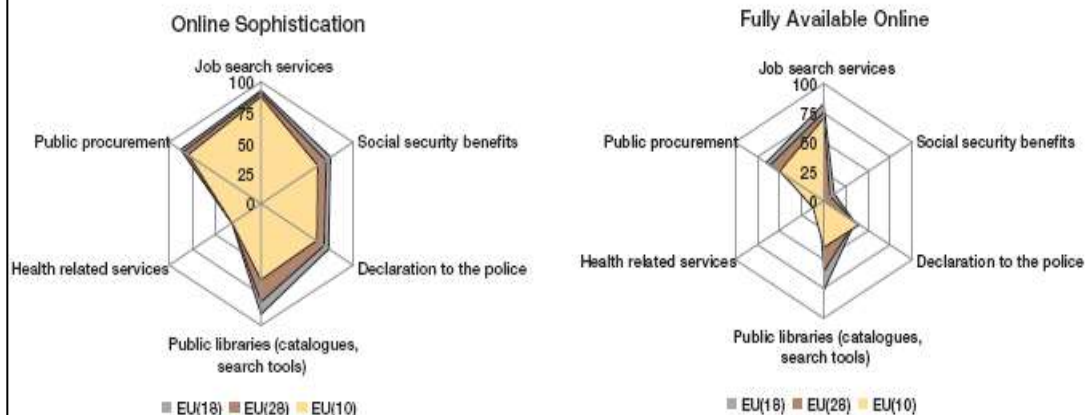

Figure 15: Returns



Online availability of Public Service: How is Europe Progressing?



Web Based Survey on Electronic Public Services
Report of the 6th Measurement
June 2006

Compared to the previous 5th measurement, Slovenia reports a bigger increase on both indicators. This results in an online sophistication for Slovenia above two-way authentication.

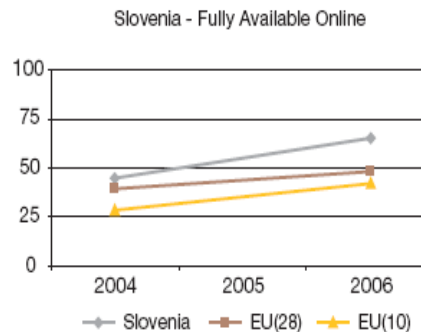
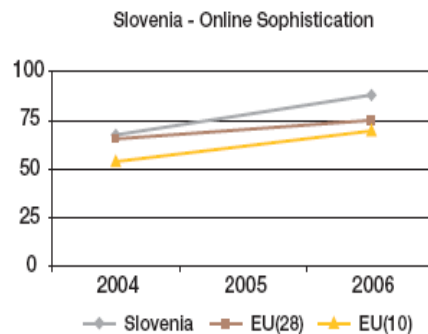

Innovative e-service developments

The portal e-VEM (<http://evem.gov.si/sp/>)—Slovenia's online one stop shop for business entities—has been in operation since 1 July 2005.



- ▶ **NL: Online public services popular in 2006** [02 May 2007]
- ▶ **PL: On-line appointments replace queuing in Czestochowa** [30 April 2007]
- ▶ **PT: eTax boom** [27 April 2007]
- ▶ **NL: Dutch tax service wins WebFlop 2007 award** [27 April 2007]
- ▶ **MT: A Recruitment Portal for the Public Service of Malta** [26 April 2007]
- ▶ **SK: Free land register portal put to the test** [23 April 2007]
- ▶ **HU: Government portal attracts 500 000 registered users** [23 April 2007]
- ▶ **ES: A new web portal for Spain's National Employment System** [23 April 2007]
- ▶ **ES: Government jobs on-line** [23 April 2007]
- ▶ **CZ: Czech Republic introduces legislation to boost eGovernment** [23 April 2007]
- ▶ **BE: Young job-seekers aided by on-line 'first job' cards** [23 April 2007]
- ▶ **UK: TV viewers use remote control to find jobs** [16 April 2007]
- ▶ **SK: Slovak Tax Authority launches eTax declarations** [16 April 2007]
- ▶ **NL: The Hague wins prestigious WebWijzer award 2007** [16 April 2007]
- ▶ **HU: eAdministration on-line in Kecskemét** [16 April 2007]
- ▶ **UK: Land Registry sets up consultation on eConveyancing** [02 April 2007]
- ▶ **UK: eGovernment for kids** [02 April 2007]
- ▶ **LI: Tax goes on-line in Liechtenstein** [02 April 2007]
- ▶ **BE: Monitoring foreign workers and lessening the administrative burden** [28 March 2007]
- ▶ **ES: Working in Spain gets easier with on-line work permits** [26 March 2007]
- ▶ **MT: Launch of the Malta and Gozo e-Tourism Portal** [21 March 2007]
- ▶ **UK: Land Registry expands its electronic payments operation** [19 March 2007]
- ▶ **AT: eGovernment working group to coordinate the implementation of the environmental information directive** [19 March 2007]
- ▶ **FR: Your personalised on-line price index** [12 March 2007]
- ▶ **ES: Tax TV** [12 March 2007]
- ▶ **DE: eTax boost** [05 March 2007]
- ▶ **LT: First eTax declarations from Lithuanian 'rural hot spots'** [26 February 2007]
- ▶ **MT: Malta to launch new children allowances eGovernment Service** [21 February 2007]
- ▶ **EU: RISERid extends 'European Registry' service** [19 February 2007]
- ▶ **ES: eAccess to town planning** [19 February 2007]
- ▶ **UK: On-line submission of tax declarations reaches new high in UK** [12 February 2007]
- ▶ **FR: Calculate your taxes on-line in France** [05 February 2007]
- ▶ **FR: On-line public administration – new 24 hour service for French citizens** [05 February 2007]
- ▶ **FI: Testing the water – ice thickness information available on the internet** [05 February 2007]
- ▶ **BE: Wallonia launches radio ad campaign to promote eGovernment services** [29 January 2007]
- ▶ **UK: London's shared school eAdmissions service gets top marks** [22 January 2007]
- ▶ **SI: Slovenian city pledges rapid-response service to citizens' questions** [15 January 2007]
- ▶ **PL: All taxpayers to submit eDeclarations by 2012** [15 January 2007]

eGovernment News - Slovenia



- ▶ [SI: Slovenia adopts eGovernment Action Plan 2010](#) [26 February 2007]
- ▶ [SI: Slovenian city pledges rapid-response service to citizens' questions](#) [15 January 2007]
- ▶ [SI: On-line and on the road – new vehicle registration service](#) [20 November 2006]
- ▶ [SI: eGovernment portal awarded the 'simplest website to use' award](#) [06 November 2006]
- ▶ [SI: A new face for Slovenian passports](#) [11 September 2006]
- ▶ [SI: Slovenia sets up central 'eCatalogue' of public information](#) [11 September 2006]
- ▶ [SI: Slovenian entrepreneurs flock to register on-line](#) [28 August 2006]
- ▶ [SI: Electronic Services of Public Administration portal launched in Slovenia](#) [14 June 2006]
- ▶ [SI: Slovenian government adopts eAdministration Strategy](#) [29 May 2006]
- ▶ [SI: Slovenia sets up e-services portal for entrepreneurs](#) [19 September 2005]
- ▶ [SI: New Ministry of Public Administration to steer e-government in Slovenia](#) [20 December 2004]
- ▶ [SI: Slovenia vows to start issuing biometric passports before US deadline of 26 October](#) [13 January 2004]
- ▶ [SI: Slovenian Government adopts a policy document on Open Source Software](#) [27 October 2003]
- ▶ [EU: The state of e-government in the accession countries \(Part 3\)](#) [30 September 2003]
- ▶ [SI: EU-supported project helps to produce a local e-government strategy in Slovenia](#) [25 April 2003]
- ▶ [SI: Slovenia implements Freedom of Information](#) [28 March 2003]
- ▶ [SI: Slovenia adopts new e-government action plan](#) [29 January 2003]



Kaj so koristi uvedbe eStoritev?



Za koga	Katere koristi
Za upravo	<ul style="list-style-type: none">○ zmanjšani stroški○ povečani prihodki○ povečana uspešnost○ povečana učinkovitost○ izboljšana dostopnost in servilnost○ skrajšano trajanje procesa
Finančne koristi za odjemalce storitev	<ul style="list-style-type: none">○ skrajšan čas za uporabnike○ znižani stroški za državljane○ znižani stroški za podjetja○ znižani stroški za posrednike○ nove priložnosti za posrednike, državljane in podjetja za drugačne dohodke○ koristi pridobljene s premikanjem vzvodov od uprave na uporabnike ter z integracijo in večjo učinkovitostjo
Socialne koristi	<ul style="list-style-type: none">○ prispevek k kvalitetnejšemu življenju državljanov, podjetij in posrednikov, ki jih je težko finančno ovrednotiti○ boljša informiranost na osnovi enostavneje dostopnih informacij○ nove poslovne priložnosti zaradi integracije javnega in privatnega sektorja
Prispevek k širšim ciljem uprave	<ul style="list-style-type: none">○ večje izkoriščanje informacijske in komunikacijske tehnologije v informacijskem gospodarstvu vključujoč izboljšave na mikro-nivoju finančnega, gospodarskega in tehnološkega razvoja○ povečanje razpoložljivosti informacij in večja dostopnost uprave

eGovernment Measurement Framework

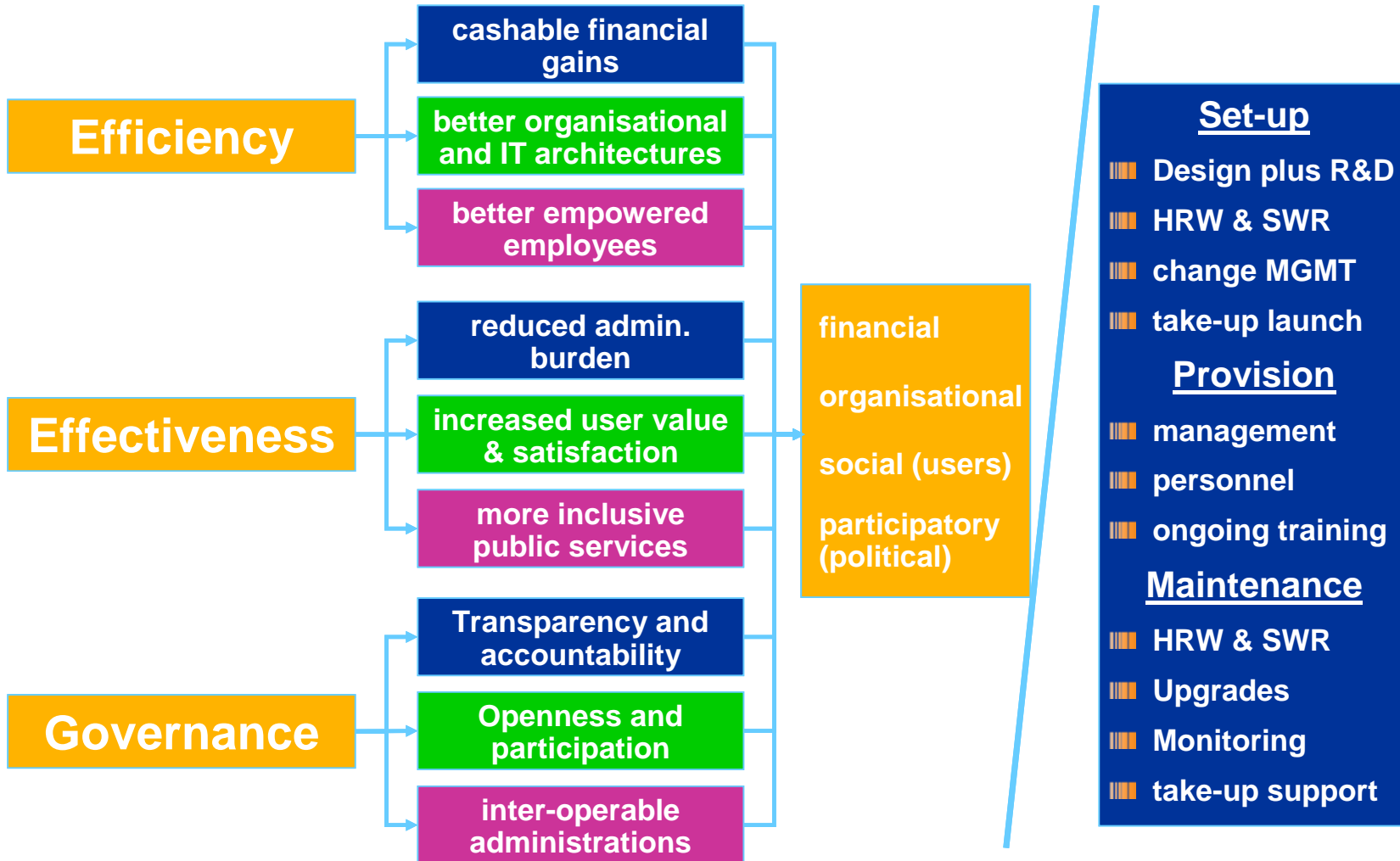

Cristiano Codagnone,
eGEP Project Manager

Measurement indicators restricted template: first run



- ▶ In short-listing indicators we are striving to maximise relevance, while minimising the cost of gathering data, and at the same time ensuring comparability

Drivers	Indicators	Best fit for
Efficiency	% Δ in throughput in a given time period	Bench-learning
	% Δ in K€ Full Time Equivalent gains	Bench-learning
	% Δ in overhead costs (paper, print, postage)	Bench-learning
Effectiveness	% Δ in time saved by citizen&business	Benchmarking
	% Δ eGovernment users satisfaction index	Benchmarking
	% Δ in usage of inclusion related e-services	Benchmarking
Governance	% Δ in transparency and accountability score	Benchmarking
	% Δ in two-ways interaction with users	Benchmarking
	% Δ in administrations using common eID	Bench-learning

Cristiano Codagnone,
eGEP Project Manager

eGovernment Measurement The Economic Impact of eGovernment

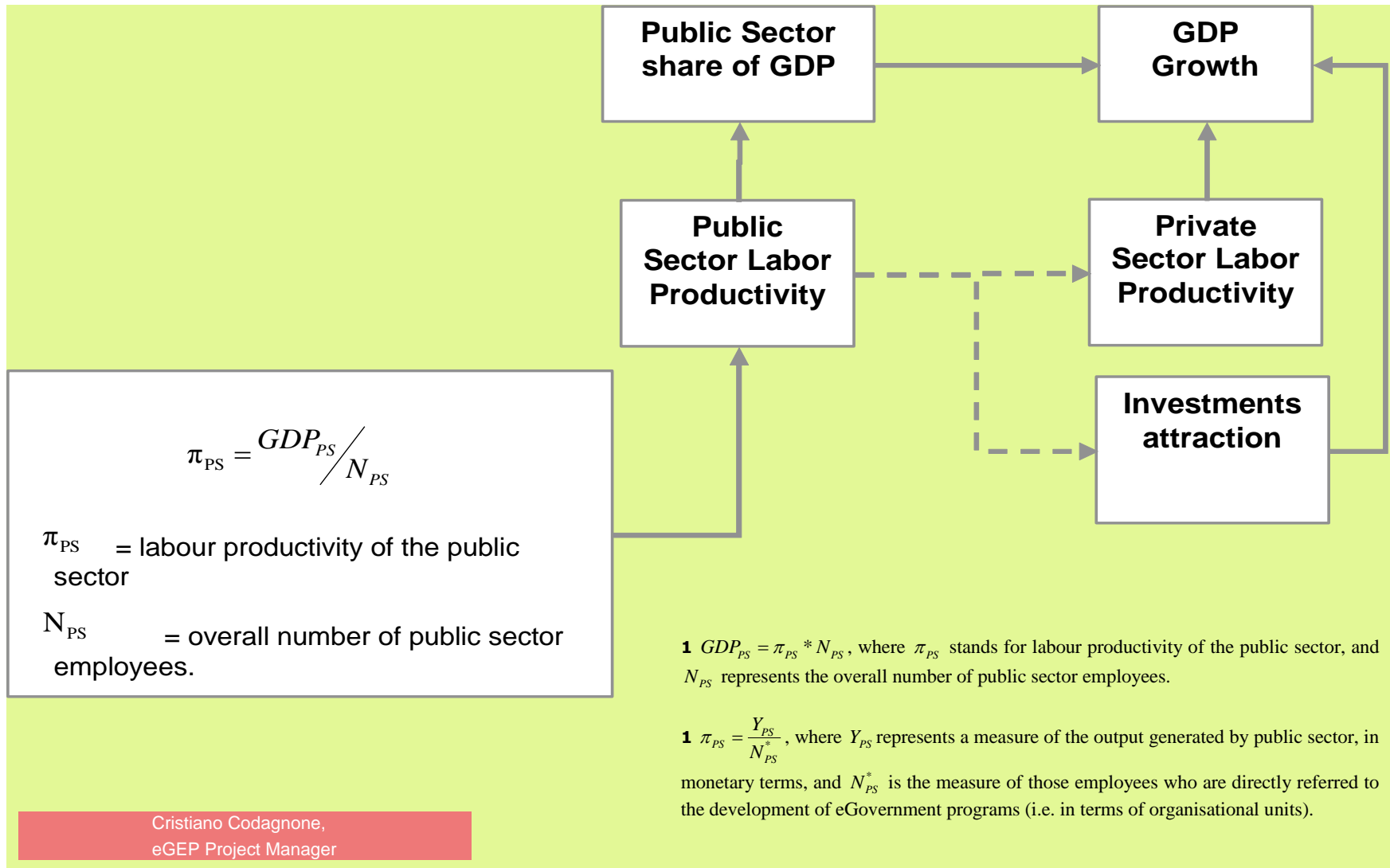

Cristiano Codagnone,
eGEP Project Manager

eGovernment Measurement The Productivity in Public Sector



The final equation for the productivity in the public sector will be the following:

$$\begin{aligned} \hat{\pi}_{PS,t} = & b \hat{Y}_{PS} + c \left(\hat{W}_{PS,t-n} - \hat{P}_{egov,t-n} \right) + d \left[\left(\hat{L}_{PS,t} + \hat{ASC}U_{t-1} + \hat{ASV}U_t \right) \right] + \\ & + e \left(\hat{E}_{hw,t-jn} + \hat{E}_{sw,t-jn} + \hat{E}_{cp,t-jn} + \hat{E}_{tp,t-jn} \right) + f (\hat{ht} + \hat{rs} + \hat{li})_t \end{aligned}$$

Example from Italy

- ▶ **Re-organisation plus online tax return (*):**
 - fewer employees (6,000) handle 5% more files
 - 10 building closed (20 mln € saving)
 - Waiting times for tax refund reduced by 50%
 - 2 mln taxpayers save 150 € per year (steady increase in users satisfaction score)

(*) 1998-2001 change over completed; comparison baseline 2000-2004

Example from Denmark

- ▶ **Re-organisation plus online companies registration:**
 - Company founding per hours went up 337% (*)
 - Waiting times went down from 37 to 16 days (*)
 - Hours needed for routine tasks went down 50% (**)
 - FTE gain went to new value added activities and development projects

(*) 1996-2003 due also to re-organisation

(**) 2000-2003 due only to online registration

Cristiano Codagnone,
eGEP Project Manager

Hvala



andja.komso@hermes-softlab.com