

Univerza  
v Ljubljani

Fakulteta  
za gradbeništvo  
in geodezijo



*Katedra za metalne konstrukcije*

# JEKLENE KONSTRUKCIJE I

## 3.0 IZDELAVA in OBDELAVA

prof. dr. Darko Beg  
Sodelavci: Blaž Čermelj

# Vlivanje



# Vlivanje

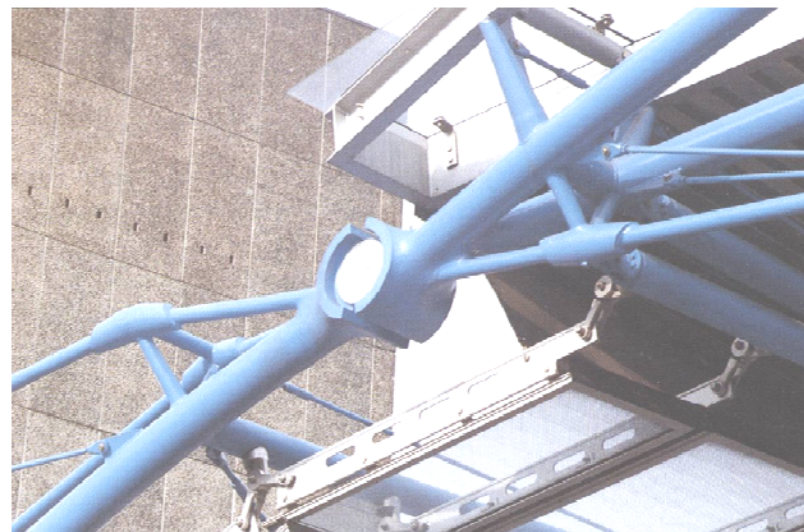
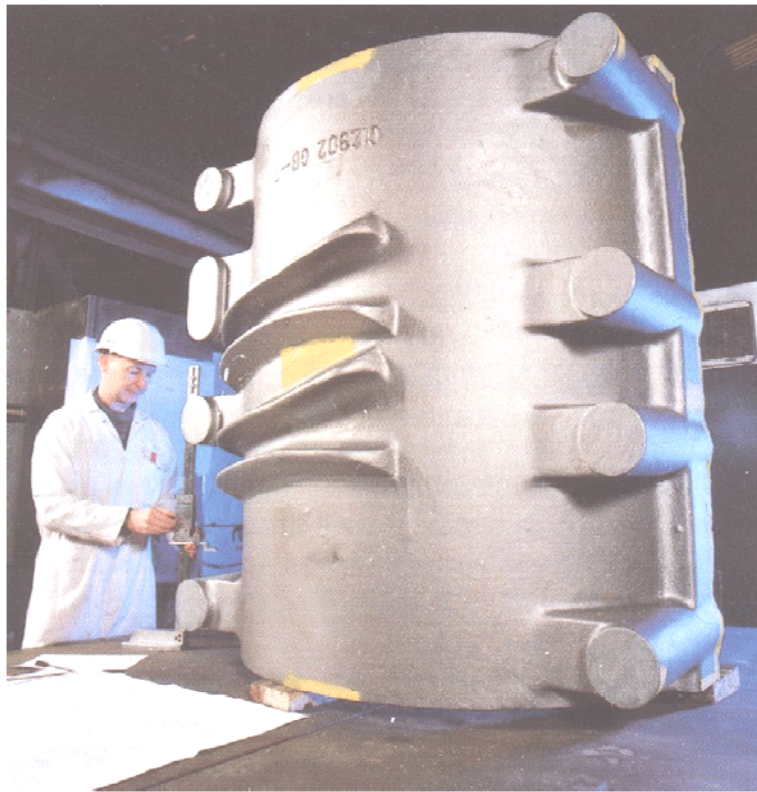



# Stiskanje

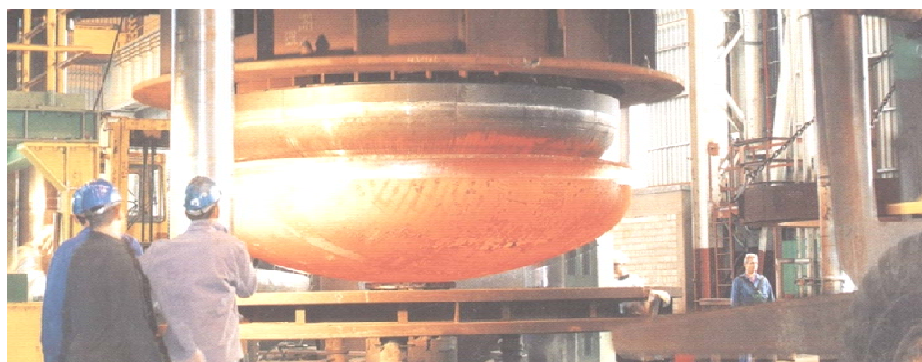



# Stiskanje



# Vroče valjanje

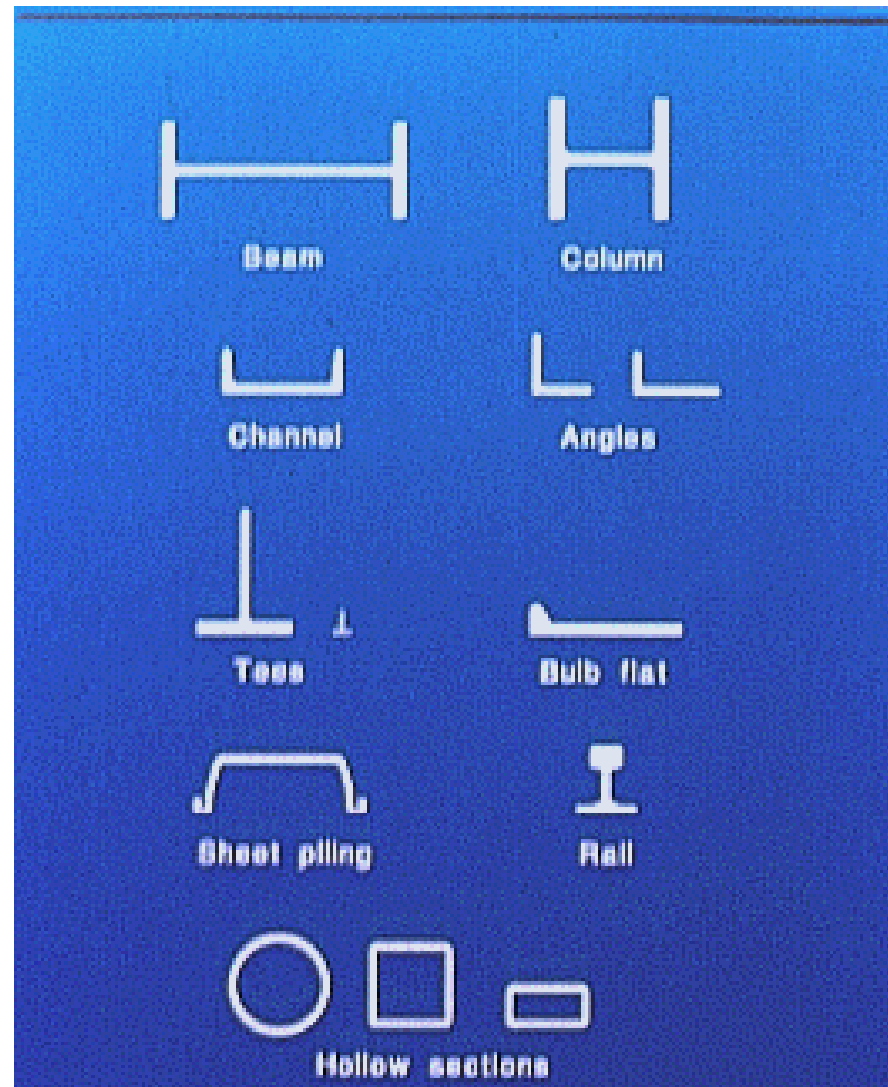

# Vročne valjanje - standardni profili

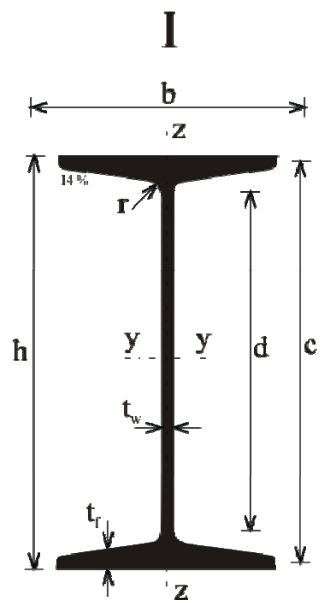

$80 \text{ mm} \leq h \leq 600 \text{ mm}$

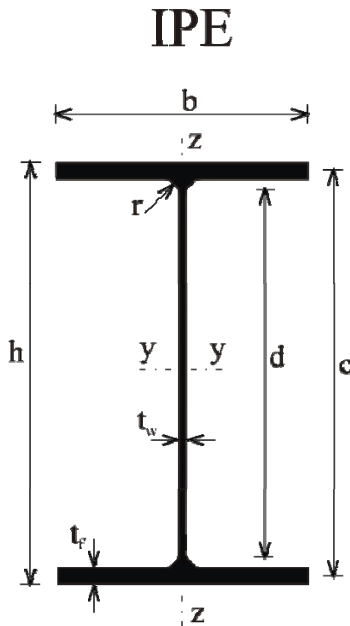

$80 \text{ mm} \leq h \leq 600 \text{ mm}$

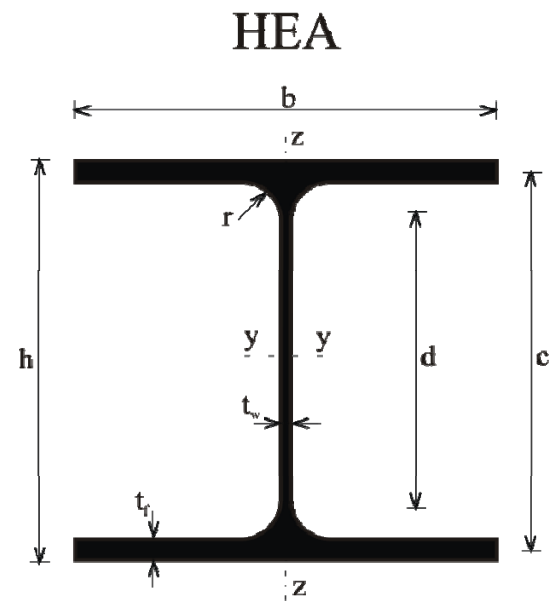

$100 \text{ mm} \leq h \leq 1000 \text{ mm}$



# Vroče valjanje - standardni profili

HEM

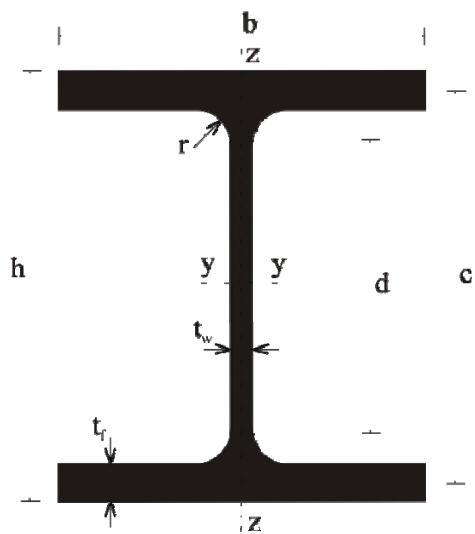

HEB

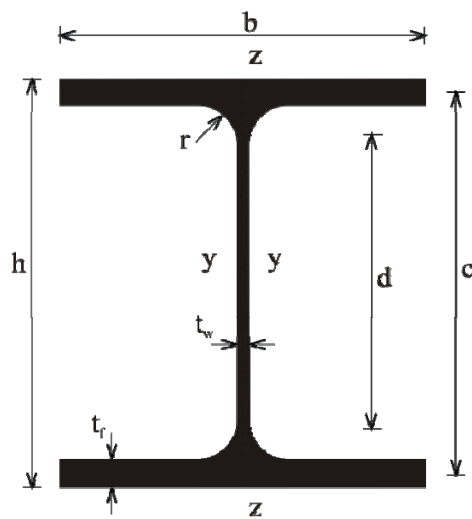

U

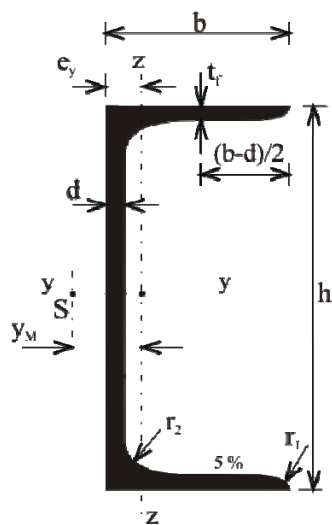

KOTNIK

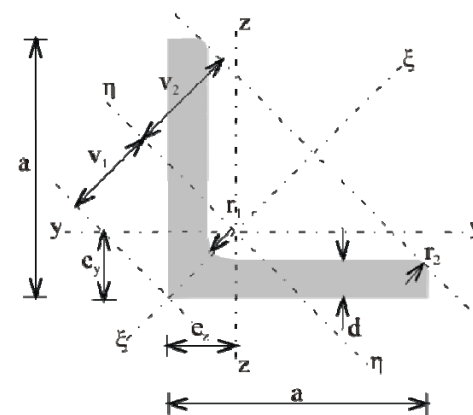









# Hladno valjanje

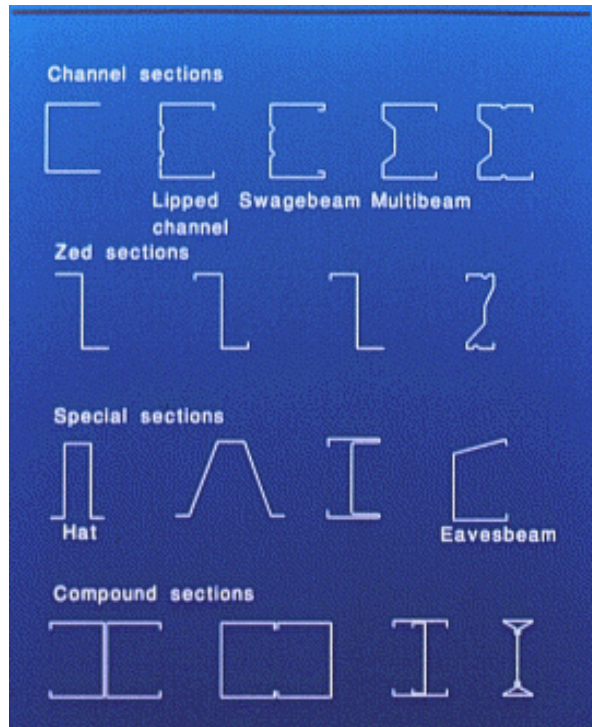



# Vlečenje – žice, vrvi, armaturne palice

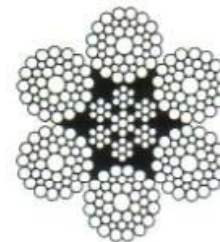
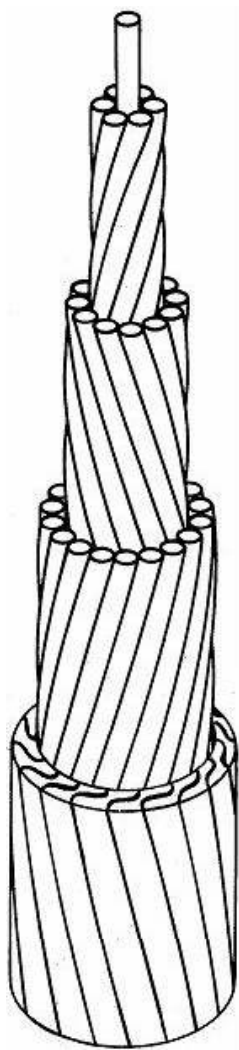
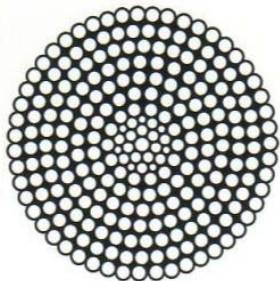



# Rezanje - žaga

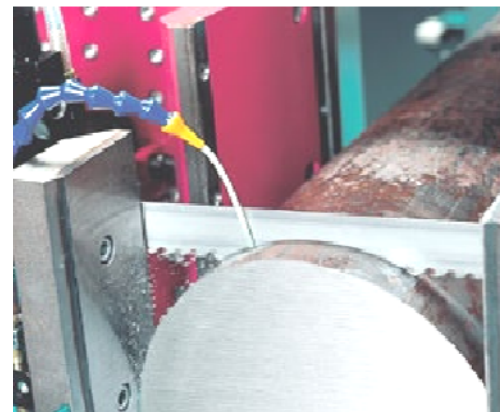
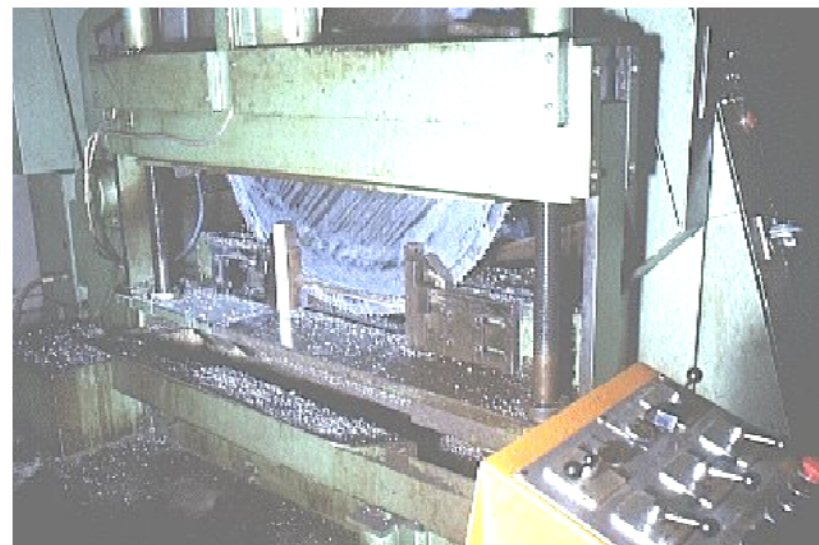

# Plamensko rezanje

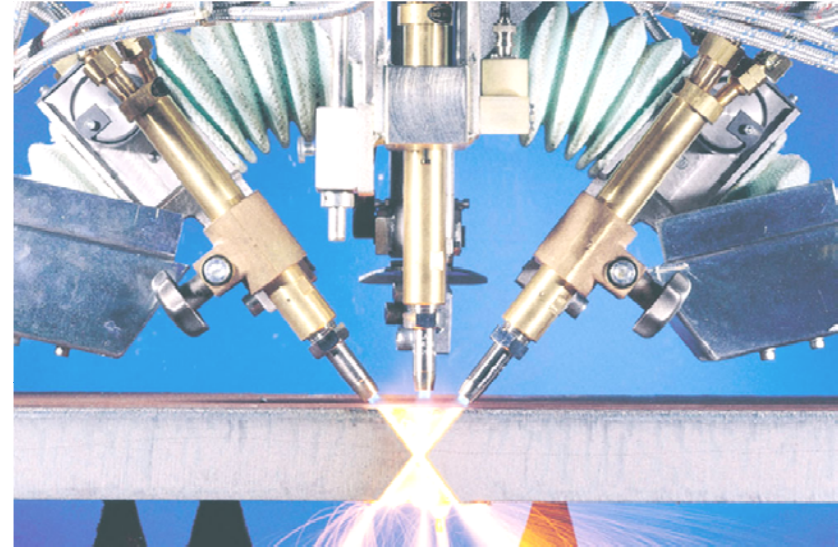
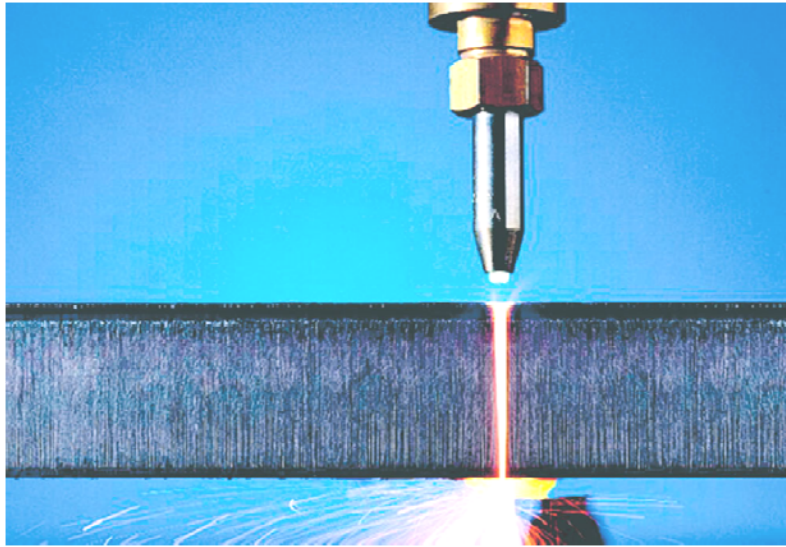



# Rezanje - plazma

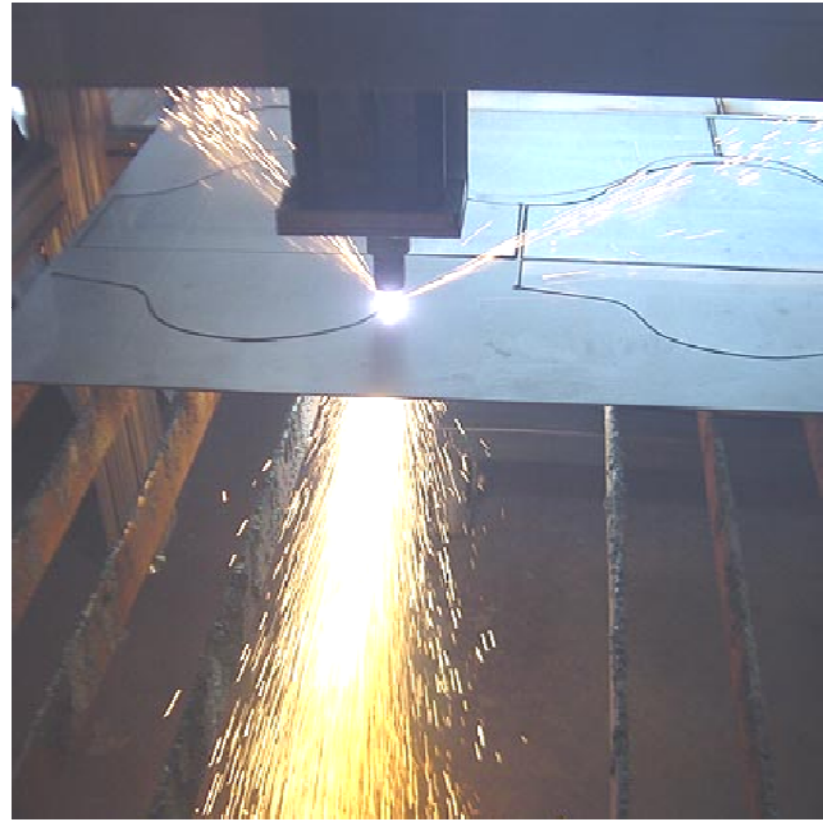



# Rezanje - laser

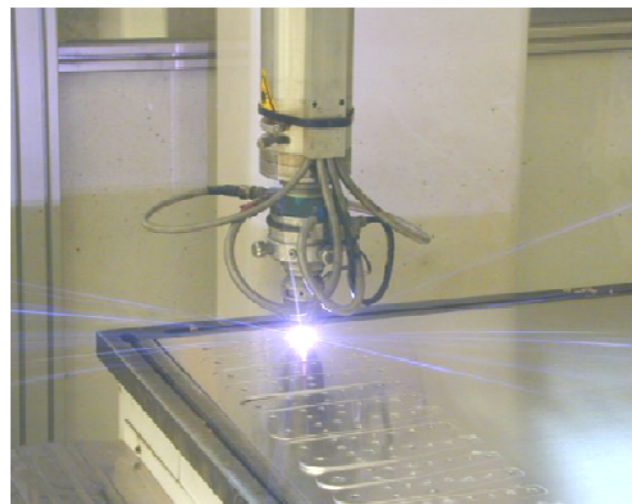
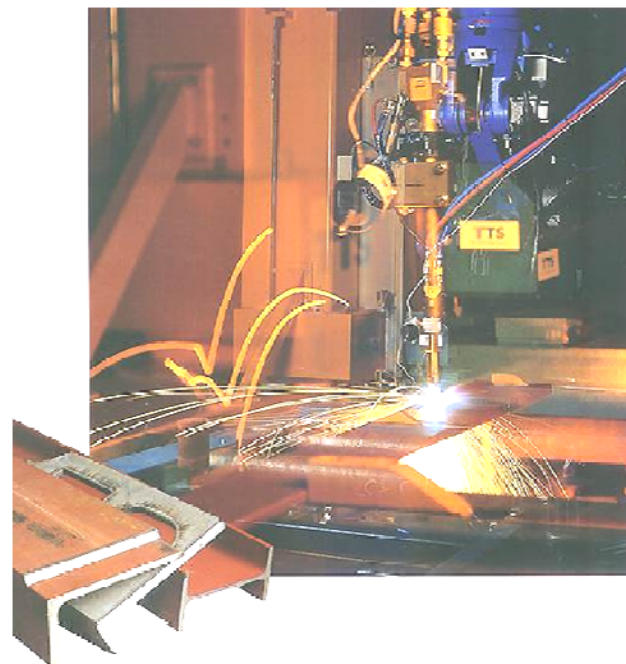
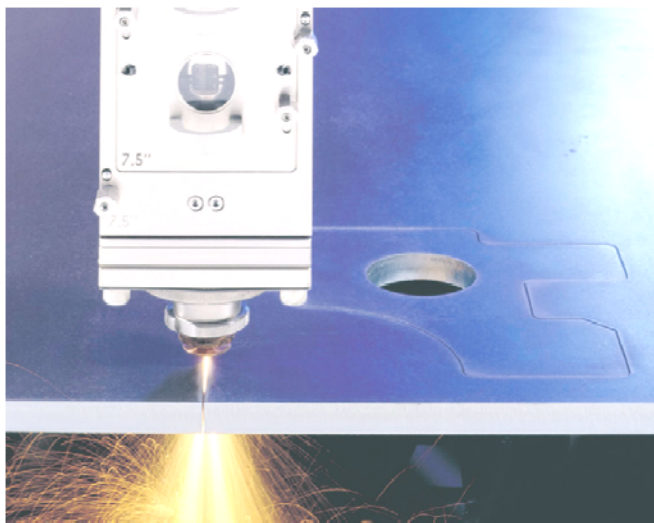

# Abrasivno vodno rezanje

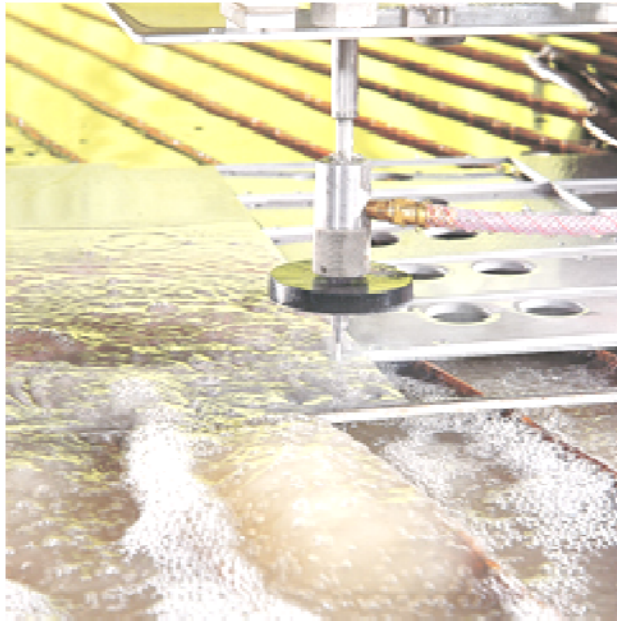

# Rezanje - škarje

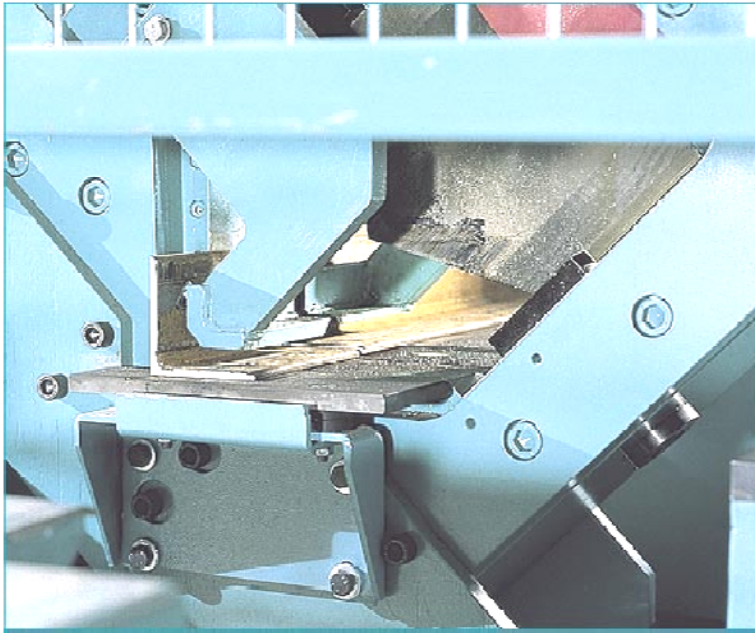



# Vrtanje

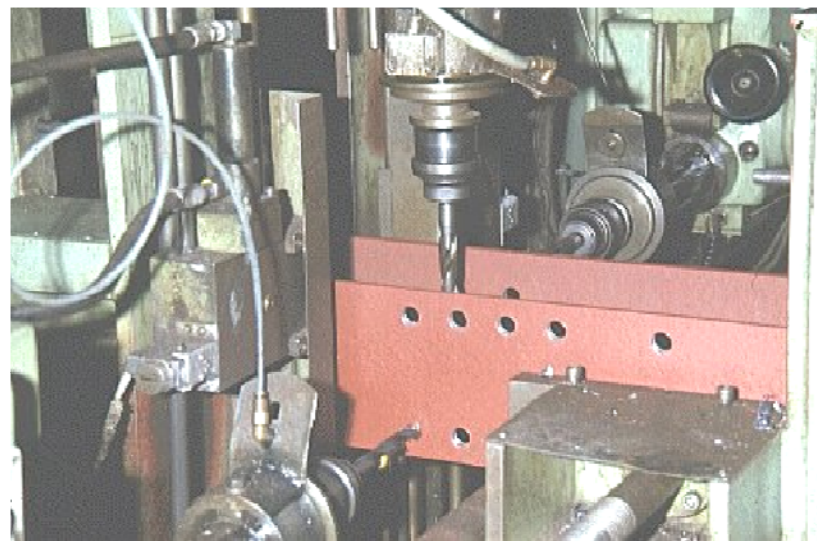



# Luknjanje - preboj pločevine

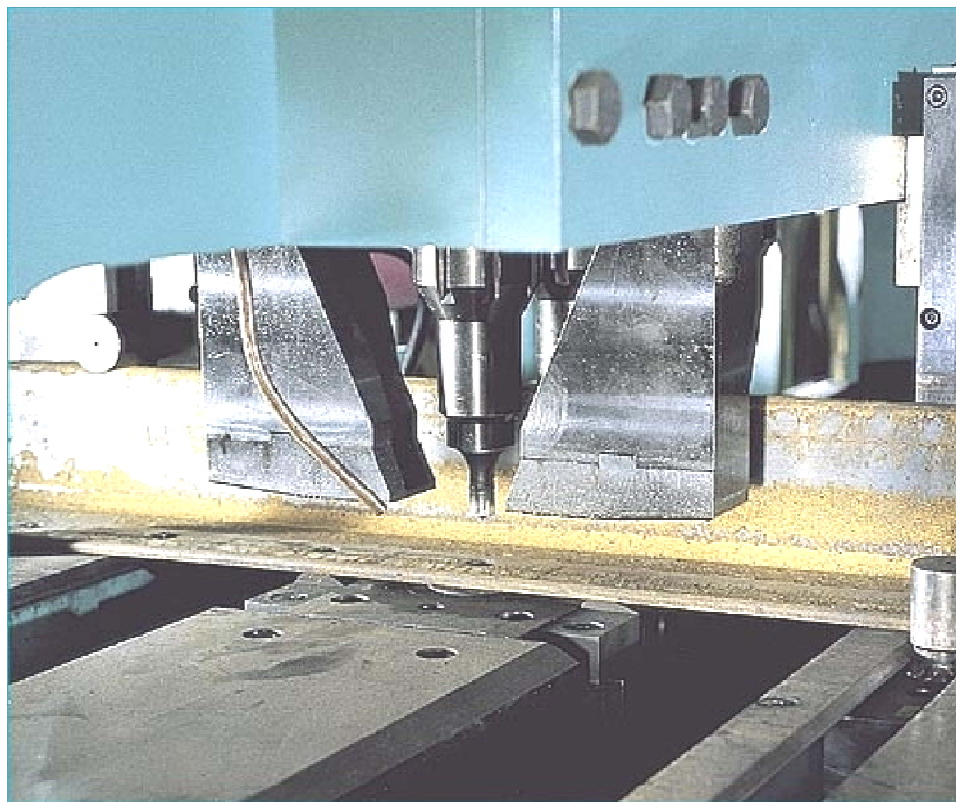

# Krivljenje

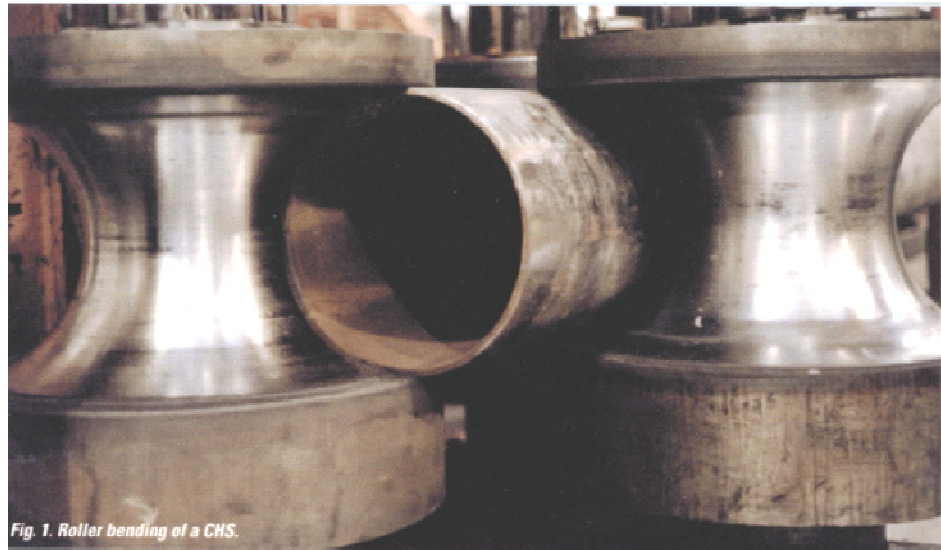
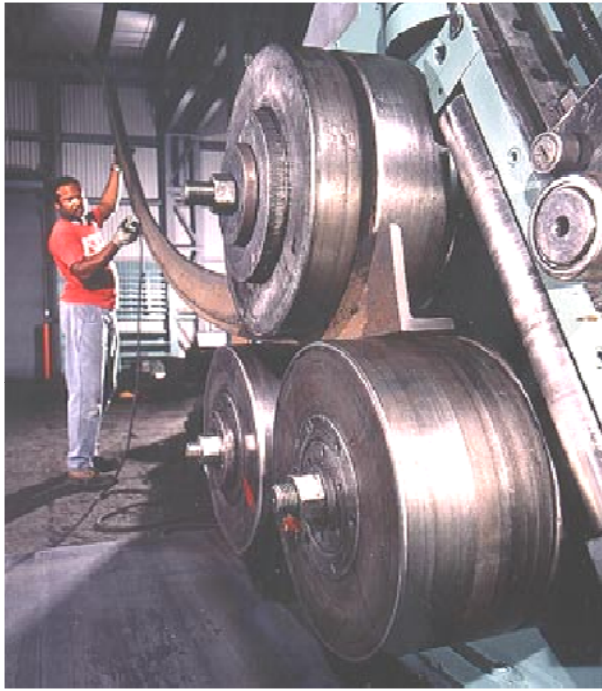
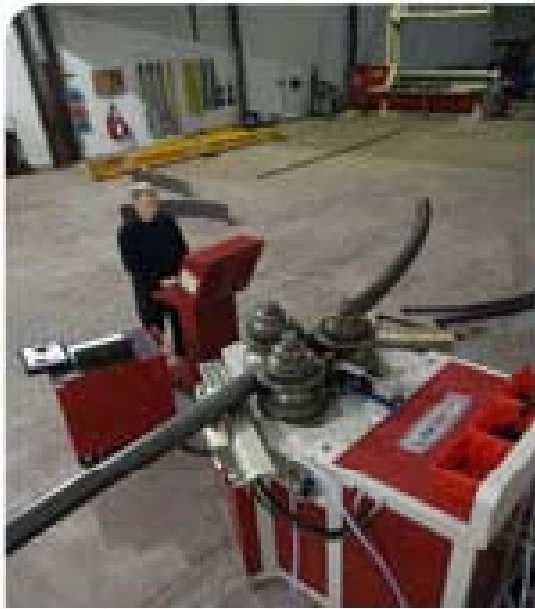

Fig. 1. Roller bending of a CHS.



# Vrste varjenja, ki se najpogosteje uporabljajo pri izdelavi konstrukcij

- Elektroobločna varjenja:
  - ročno varjenje z oplaščeno elektrodo;
  - polavtomatsko varjenje v zaščiti CO<sub>2</sub>;
  - avtomatsko varjenje pod praškom.
- Uporovno varjenje čepov za sovprežne konstrukcije.
- Avtogeno varjenje.



# Varjenje

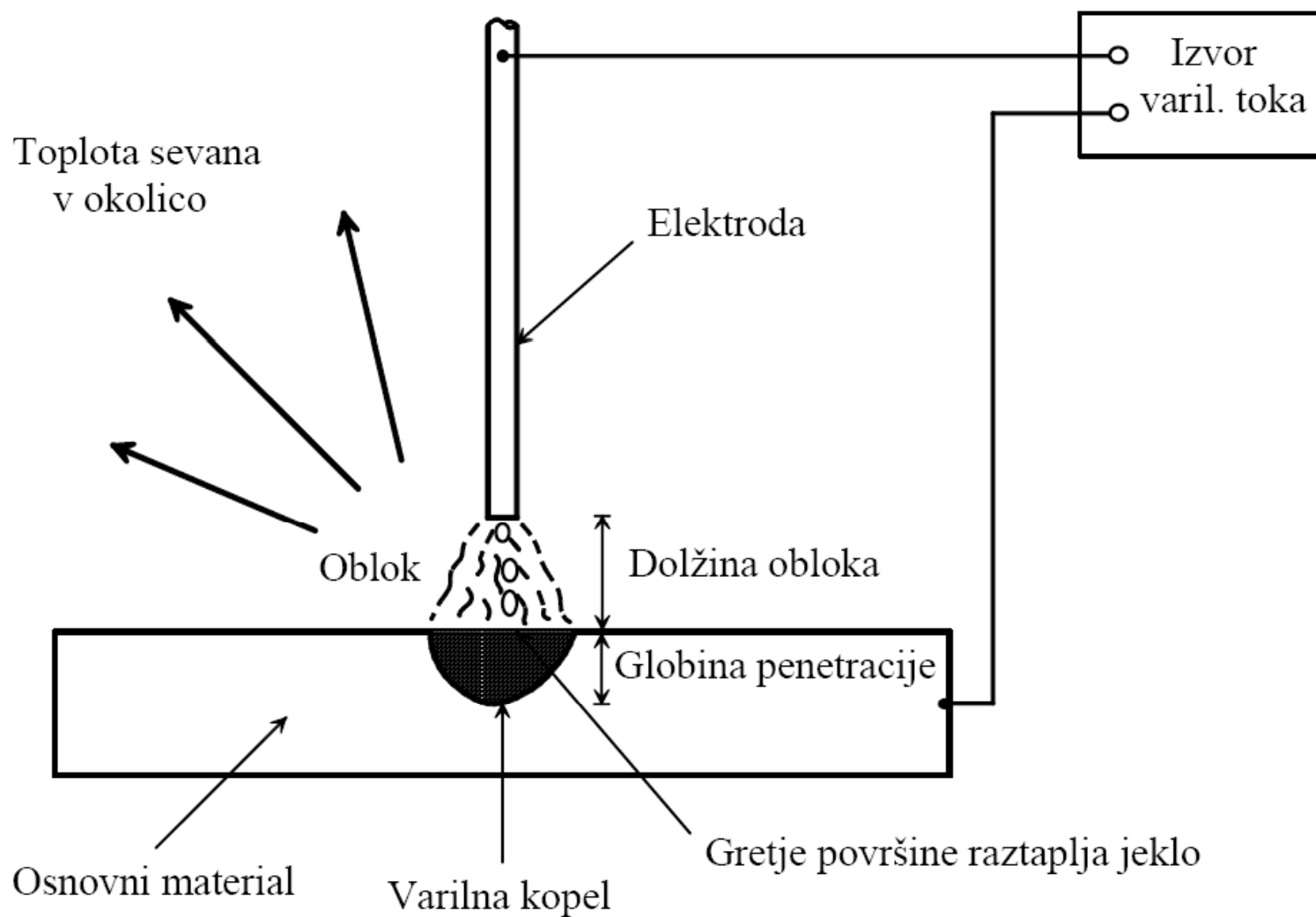

Princip elektroobločnega varjenja

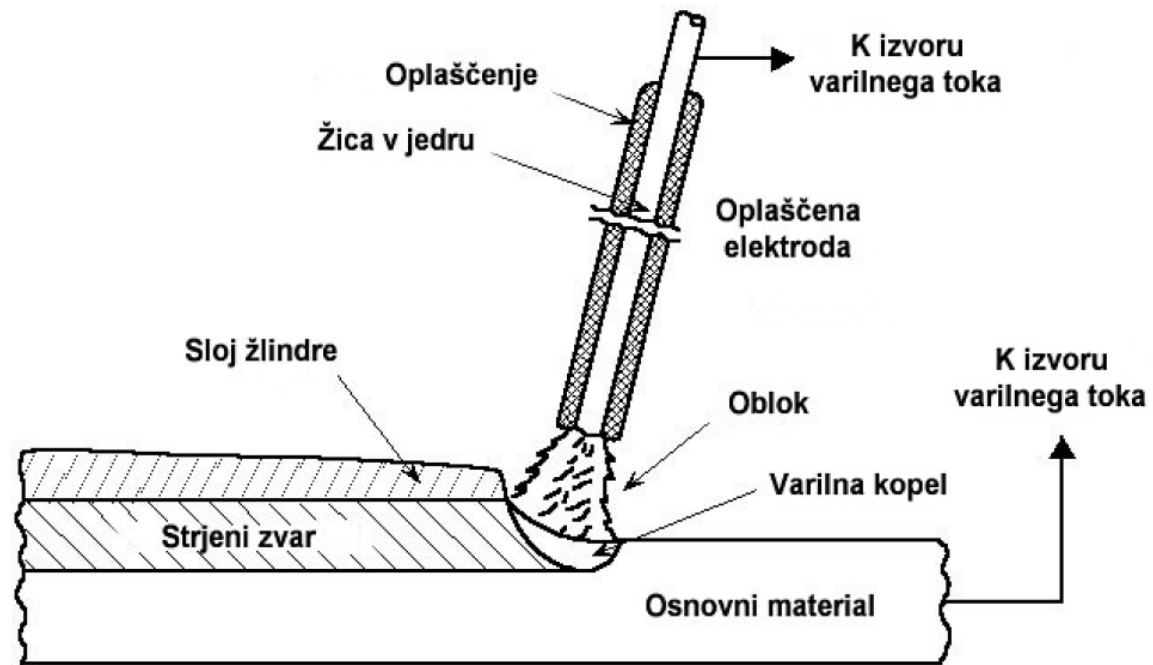

Ročno varjenje z oplaščeno elektrodo







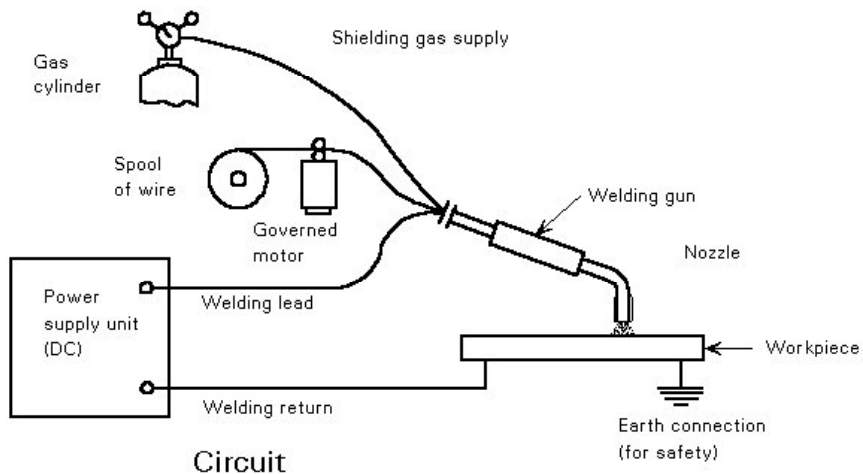

## Elektrode za varjenje

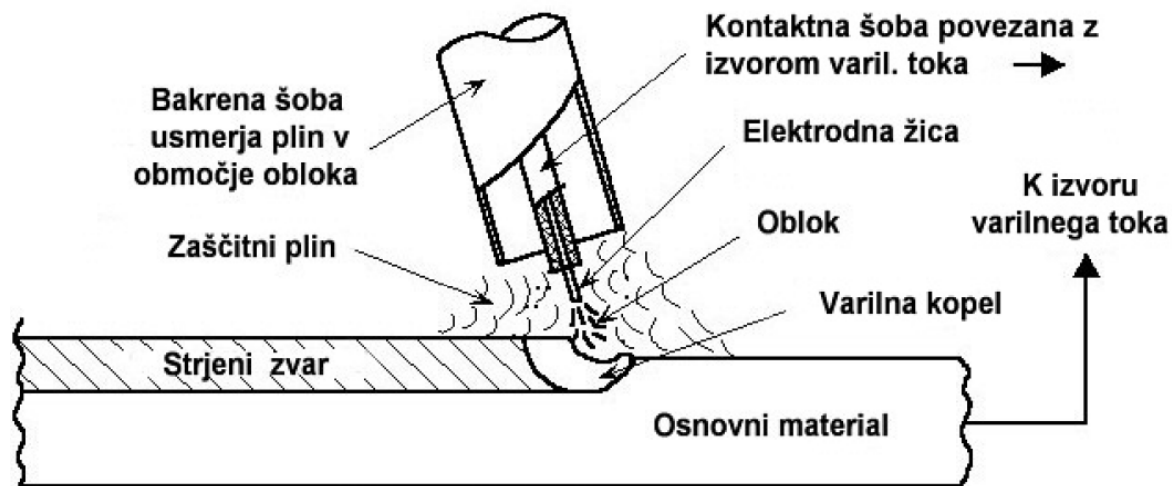
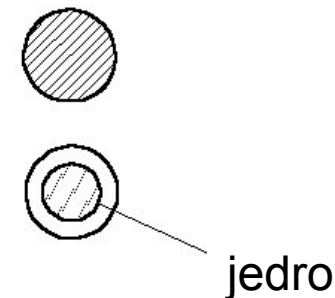

## Polavtomatsko varjenje v zaščiti CO<sub>2</sub> (MAG)

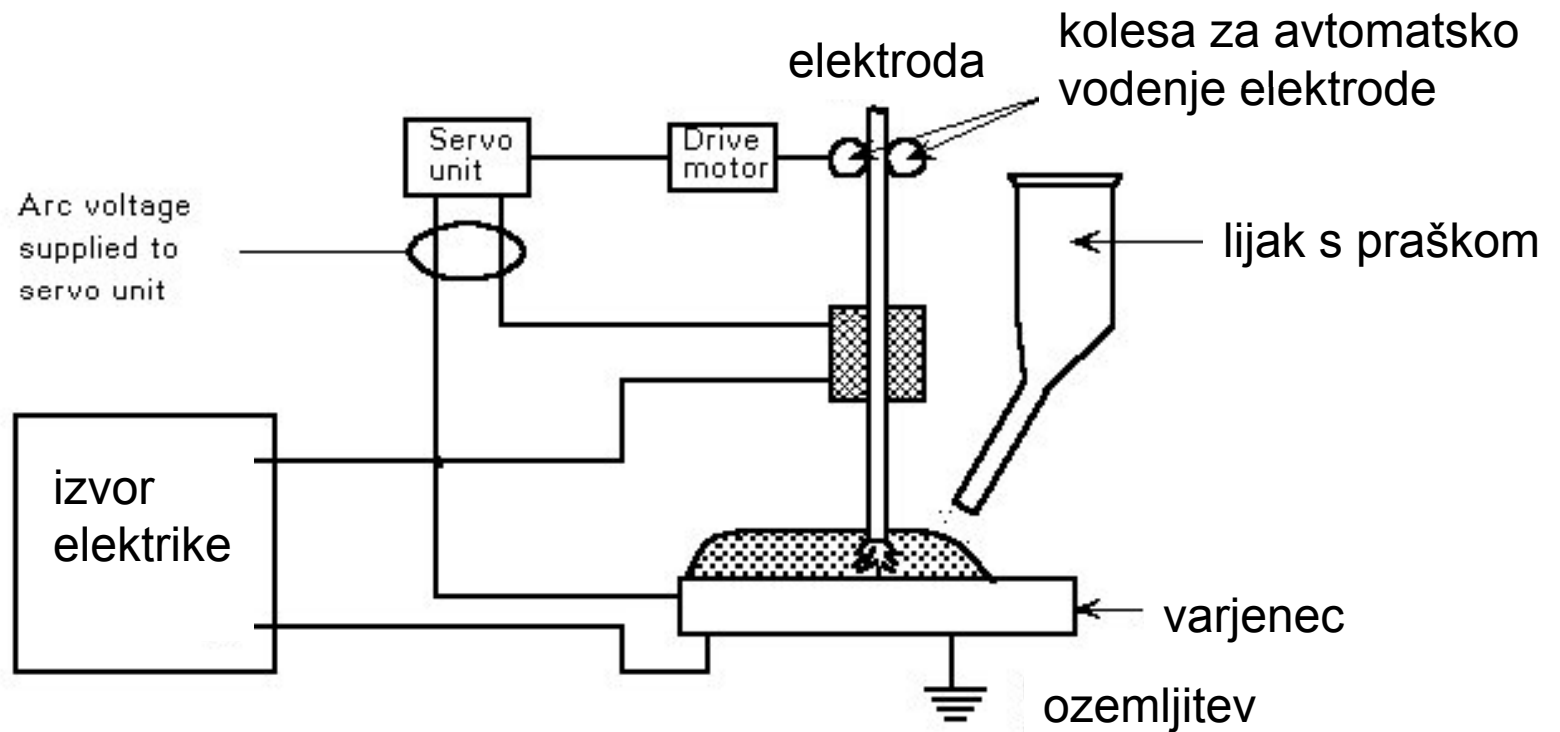

Avtomatsko varjenje pod praškom



# Ročno in polavtomatsko varjenje

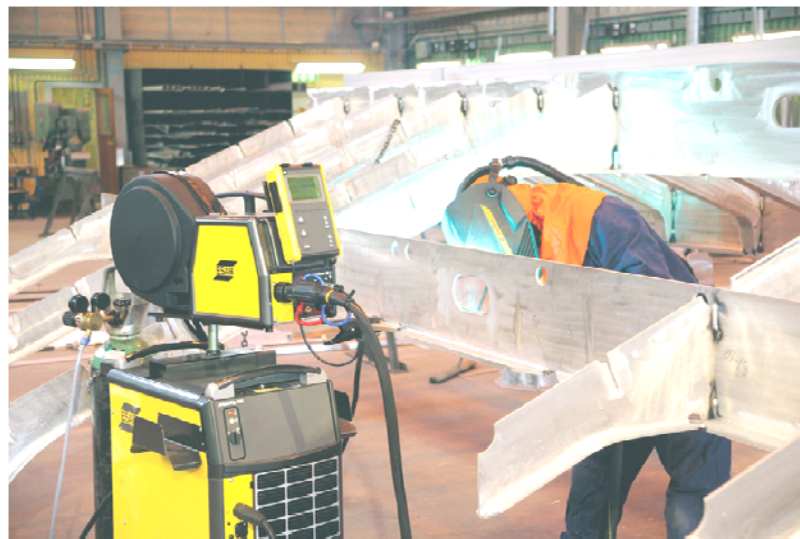
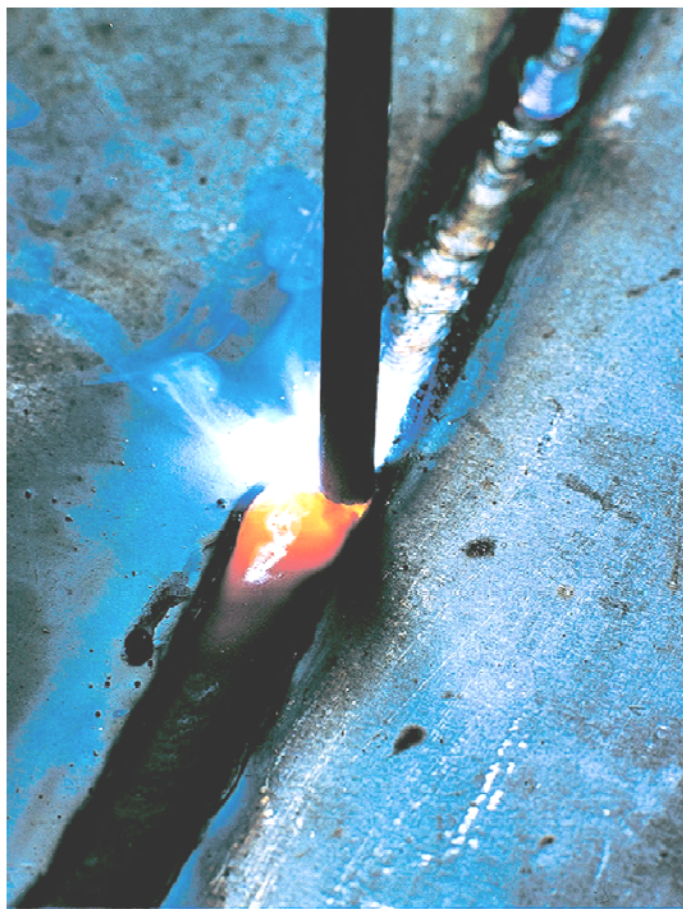

# Avtomatsko varjenje pod praškom





# Avtomatsko varjenje pod praškom

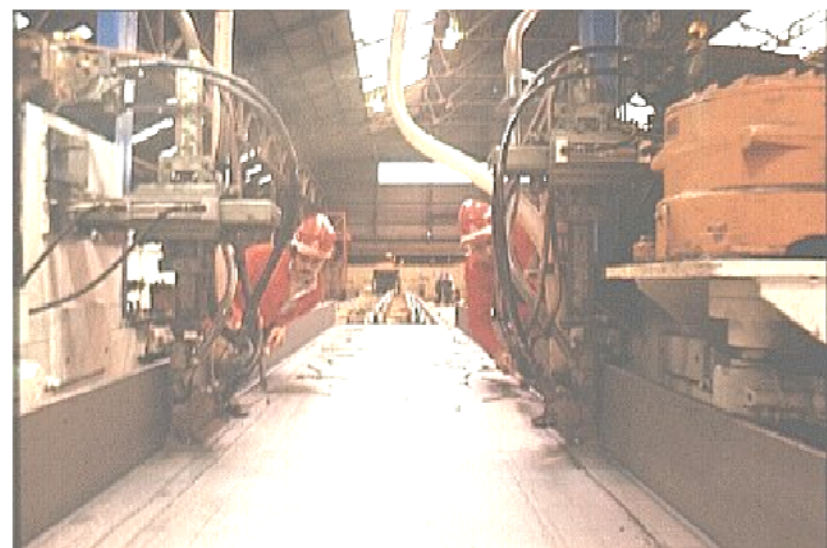
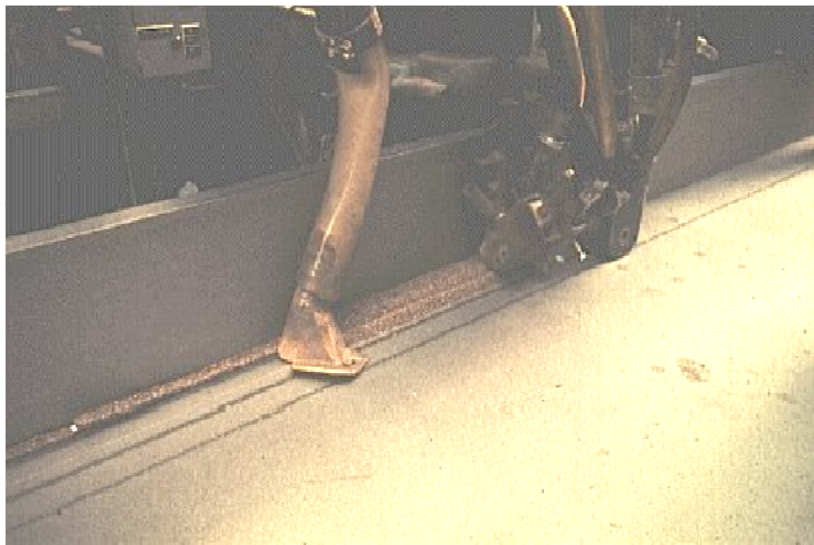



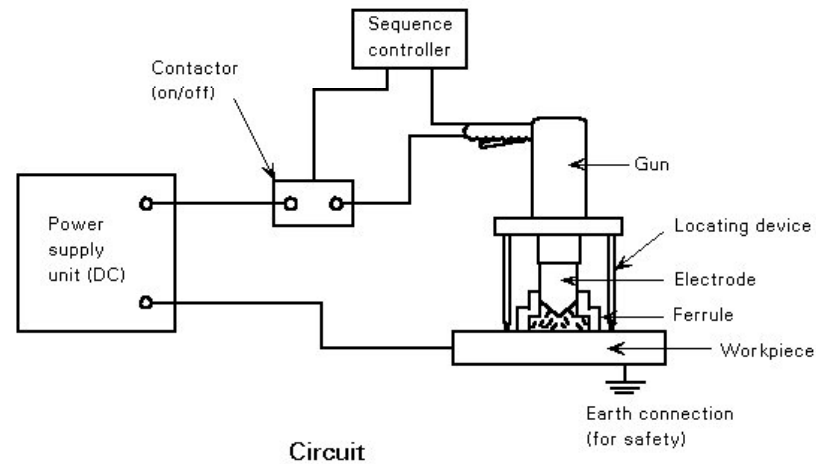

---

Electrode : Studs with ends prepared for welding by manufacturer

---

Ceramic ferrules : shaped to suit stud profile

---

Controls : Current - preset at power supply unit  
 Voltage - vary during welding in a sequence  
 Electrode feed - determined by the control unit  
 Location - controlled by operator

---

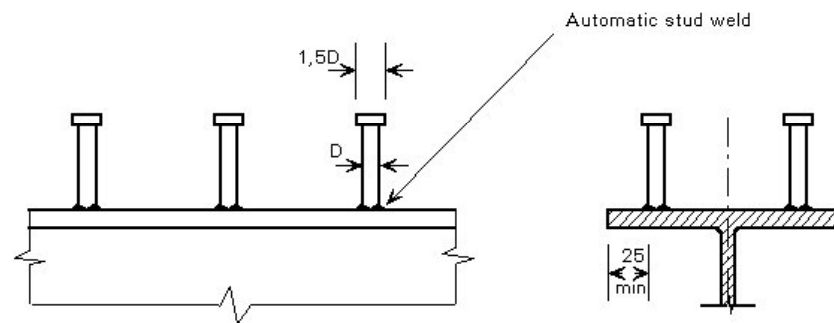

## Uporovno varjenje moznikov

# Uporovno varjenje – varjenje čepov

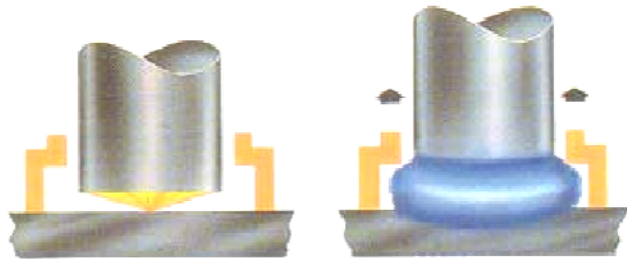

1. Stud & ceramic ferrule against the work plate.

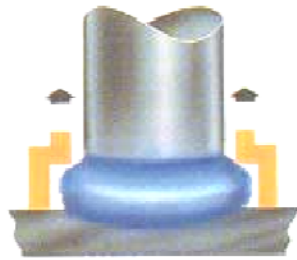

2. Stud lifts and arc is drawn.

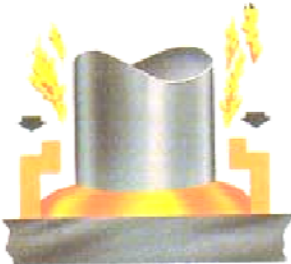

3. Control times out and stud plunges into molten steel.



4. Metal solidifies and weld is completed in milliseconds.



# Razvoj toplotno vplivne cone

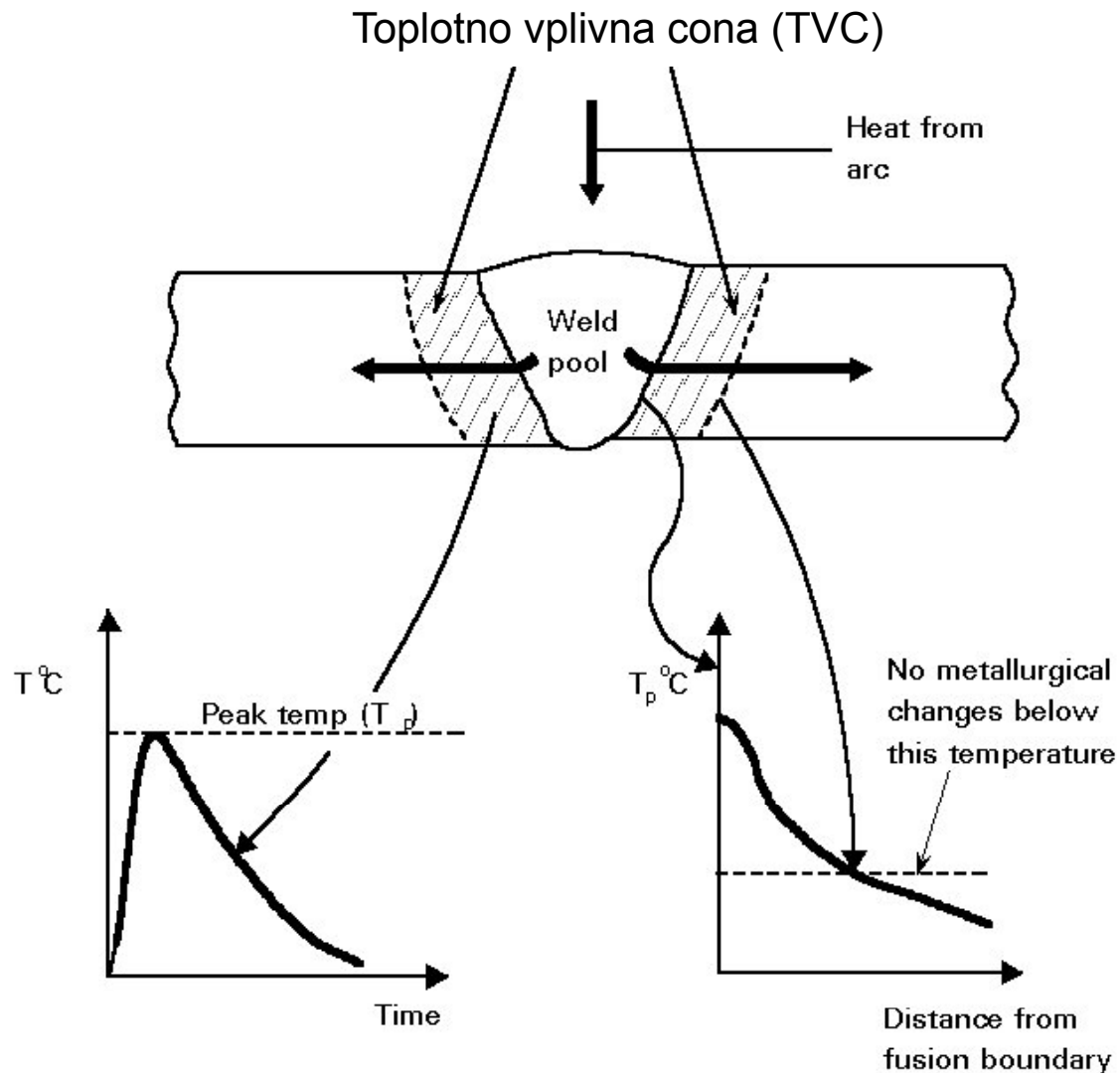

Segrevanje in ohlajevanje v TVC

Sprememba temperature v TVC



# Vrste spojev

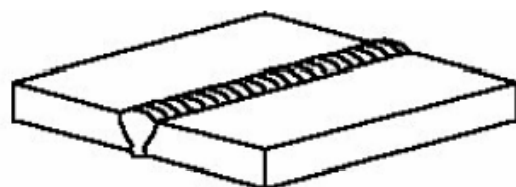

čelni zvar

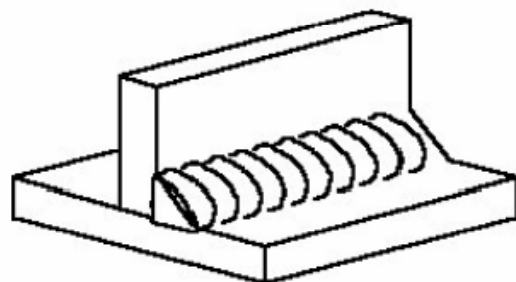

kotni zvar

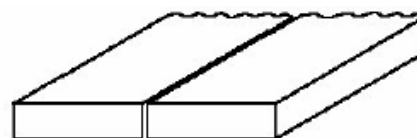

Čelni stik - enak

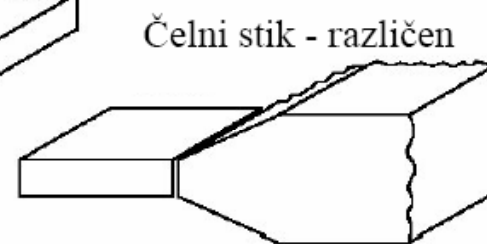

Čelni stik - različen

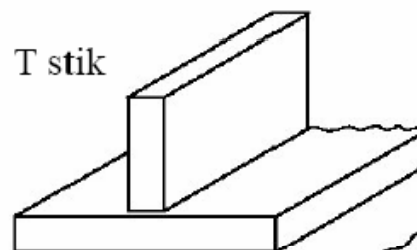

T stik

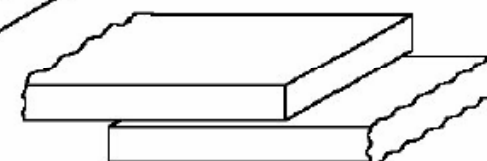

preklopni stik

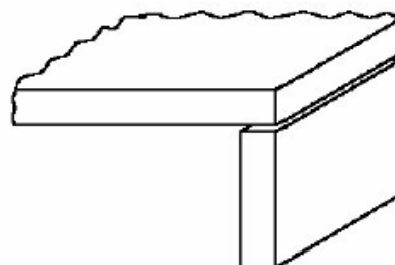

vogalni stik - zaprt

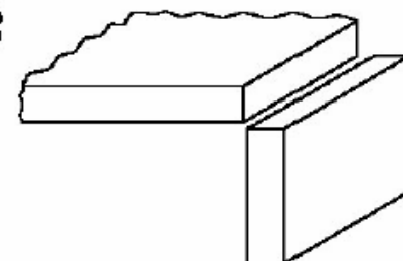

vogalni stik - odprt

# Priprava žleba za čelni zvar

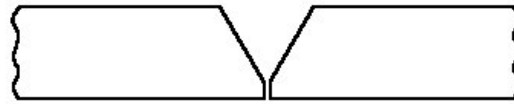

Single Vee

Tanjše pločevine

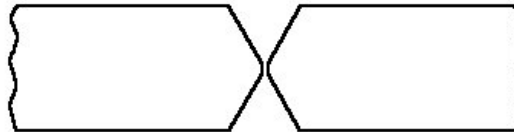

Double Vee

Debelejše pločevine

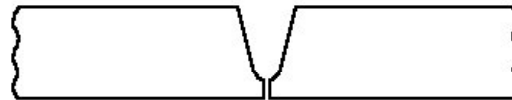

Single U

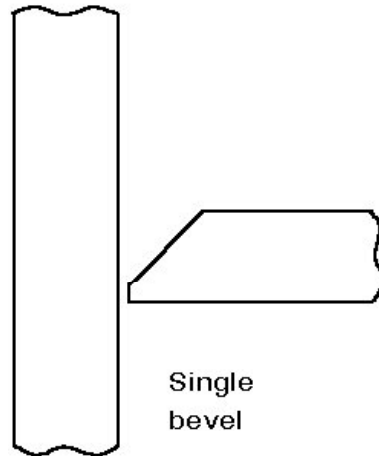

Single  
bevel

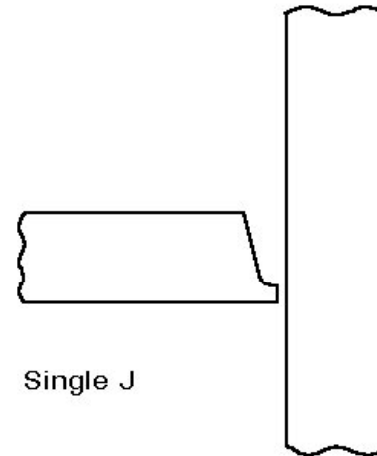

Single J

# Izvedba zvarov pri obločnem varjenju

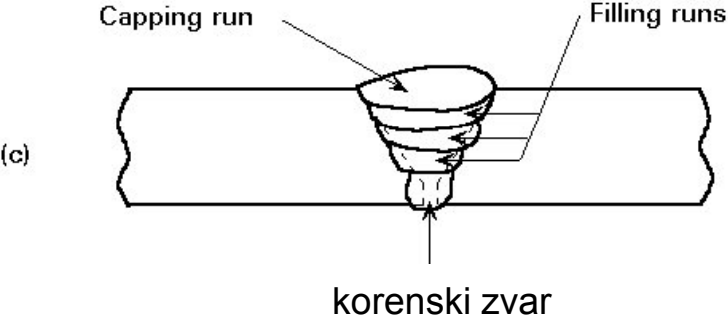
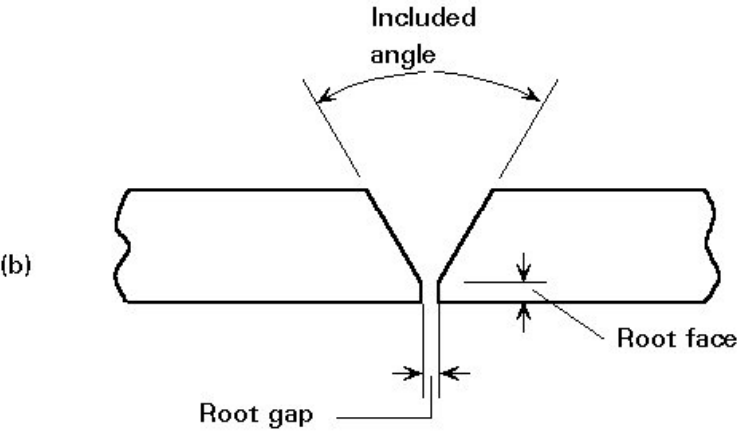
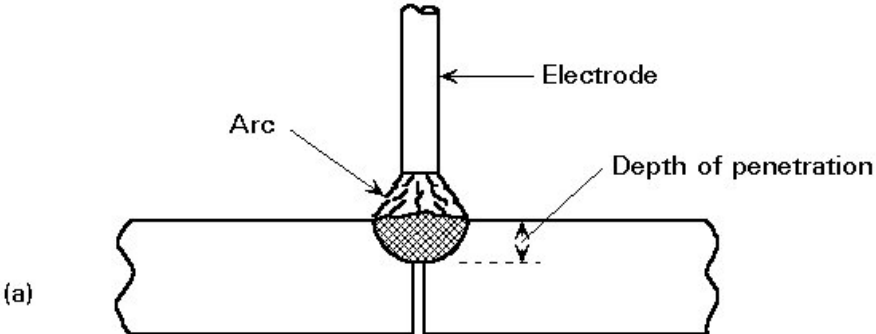



# Izvedba korenskega zvara

Koren zapolnjen z zvarom

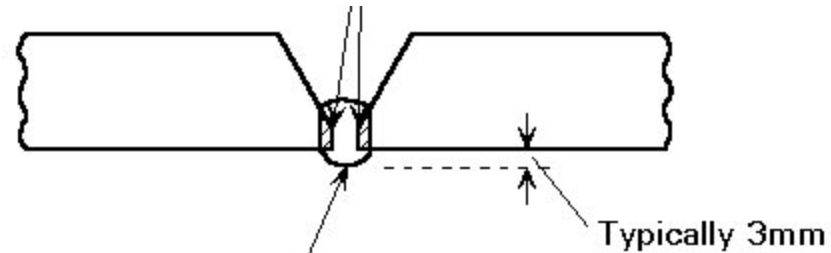

Penetration bead must not be too wide, otherwise weld pool will collapse

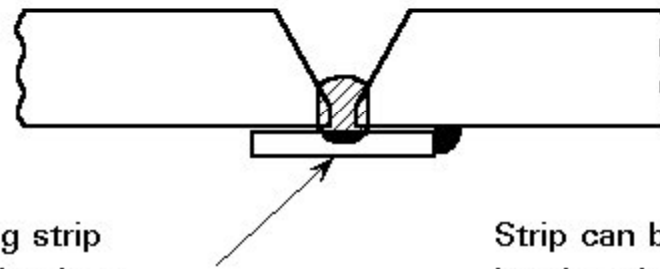

Steel backing strip may be left in place or removed after welding (depends on code)

Strip can be held in place by short lengths of fillet weld

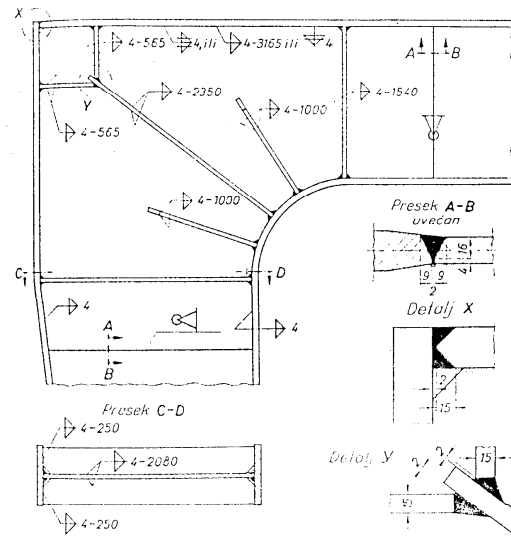

31. 54

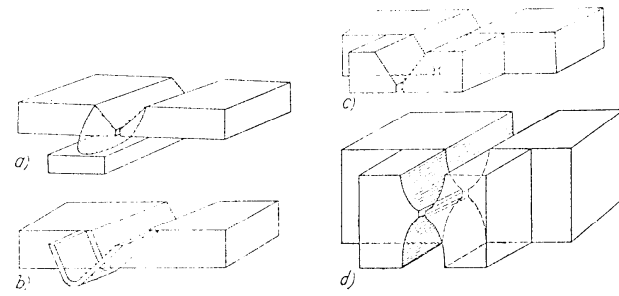

31. 55

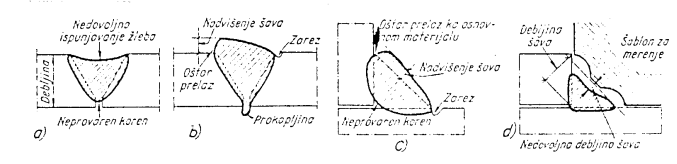

31. 56

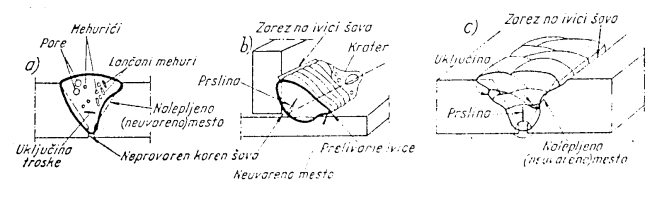

31. 57

# Zaostale napetosti

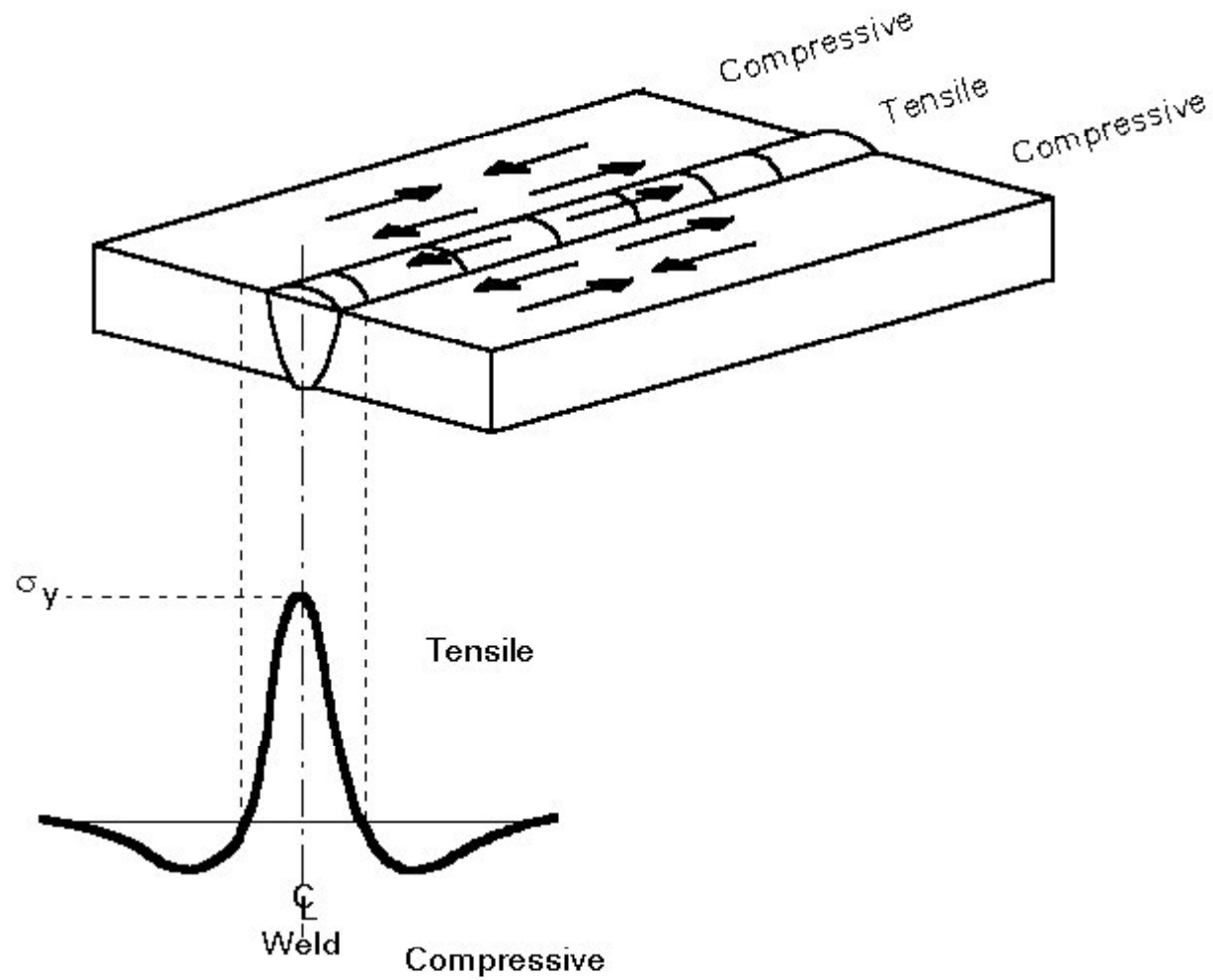



# Deformacija pločevine zaradi varjenja

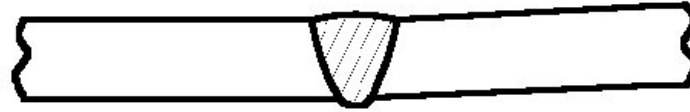

Angular distortion in single vee butt

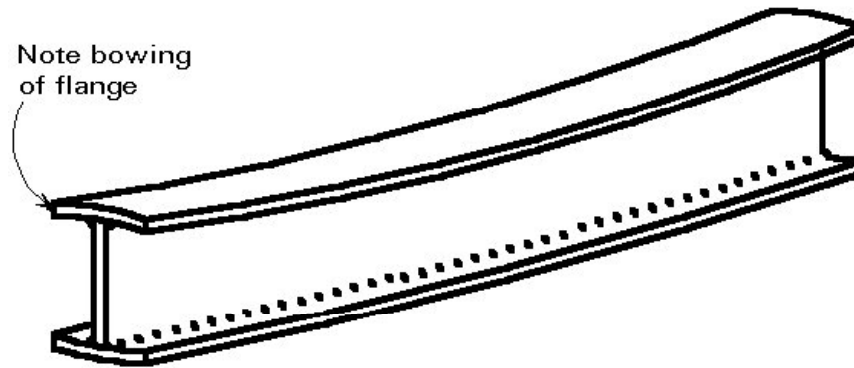

Longitudinal bowing in welded beam

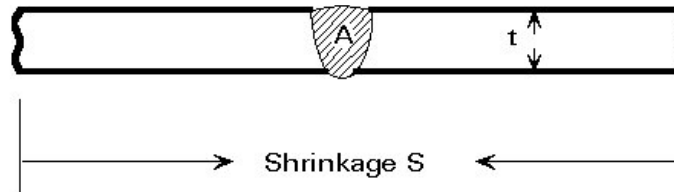

$$S = \frac{kA}{t}$$

k = Empirical factor  
(0,1 to 0,17)

A = Cross-section of  
weld

t = Thickness of plate

# Pravilni potek varjenja brez deformacije pločevine

Angular distortion



Double vee better than single vee



Single u better than single vee

Longitudinal bowing

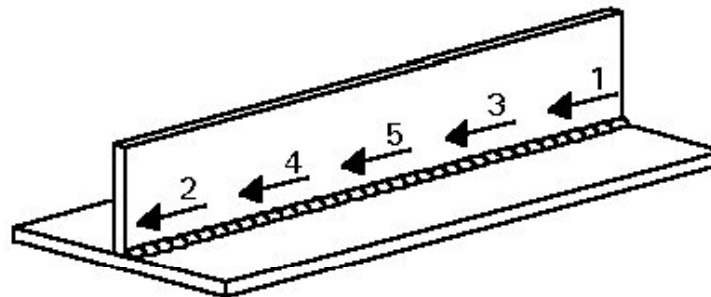

Welding in short lengths reduces longitudinal bowing but increases welding costs

# Kontrola zvarov - porušne kontrole; kontrola varilcev, varilne opreme in varilnih postopkov

Natezni test

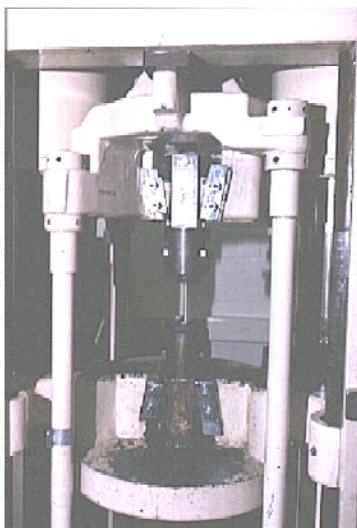

Upogibni test

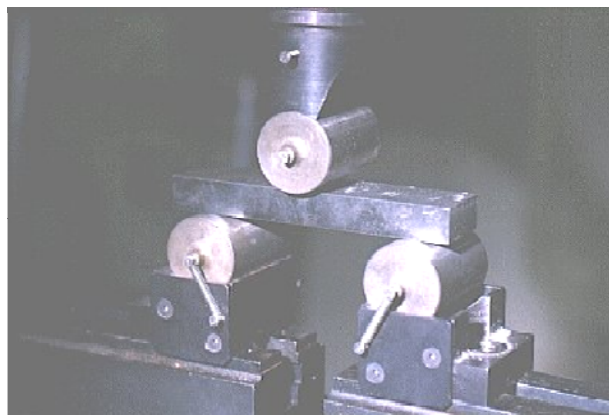

Charpy-jev test  
(lomna žilavost)

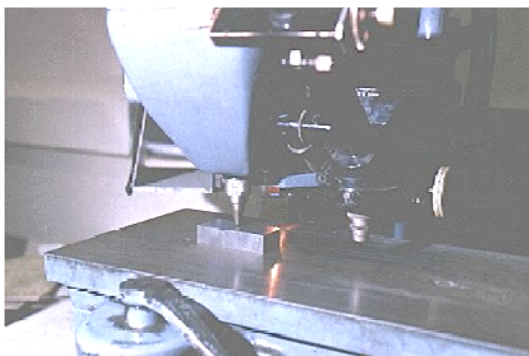
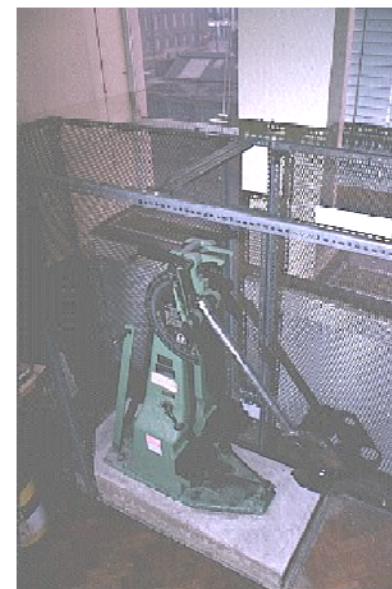

Test za določitev  
trdote



# Zvar in toplotno vplivna cona (HAZ)

- metalografski vzorec

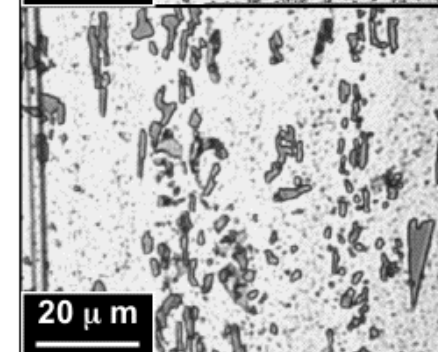
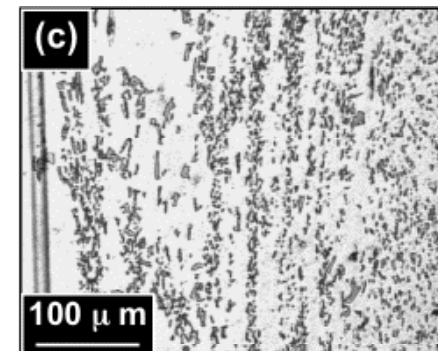
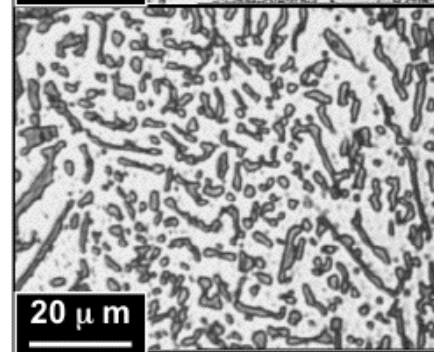
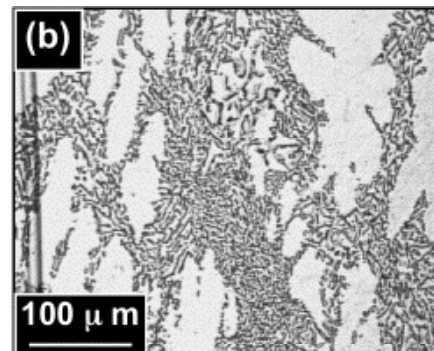
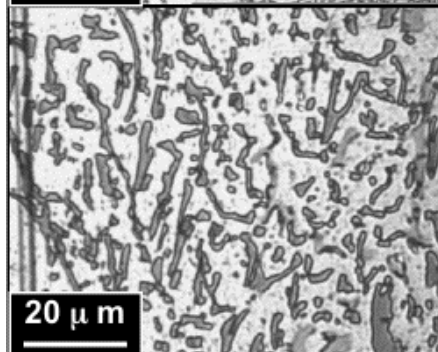
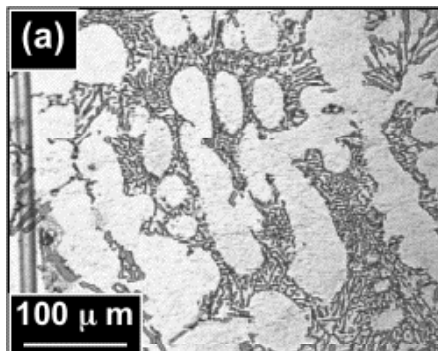
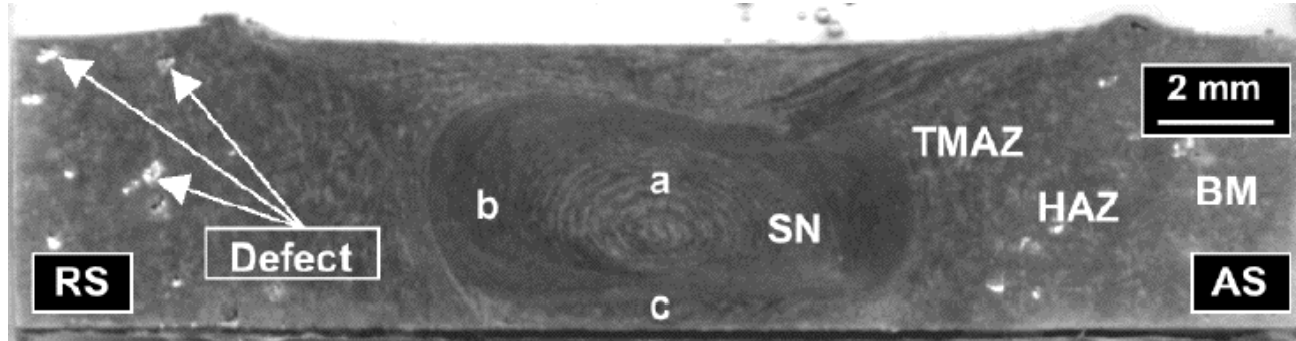



# Kontrola zvarov

- Neporušne metode se uporabljajo za kontrolo zvarov v konstrukciji:
  - vizualna kontrola;
  - kontrola s penetracijo;
  - magnetna kontrola;
  - kontrola z ultrazvokom;
  - kontrola z rentgenom.

# Kontrola zvarov - neporušne metode



Vizualna kontrola zvarov - orodje za kontrolo dimenzij zvarov.

Ugotovimo, če je zvar sploh izdelan, če je izdelana prava vrsta zvara, preverimo geometrijo in površinske napake.

Vizualna kontrola se izvede za vse zware najmanj 16 ur po zaključku varjenja

# Kontrola zvarov - neporušne kontrole

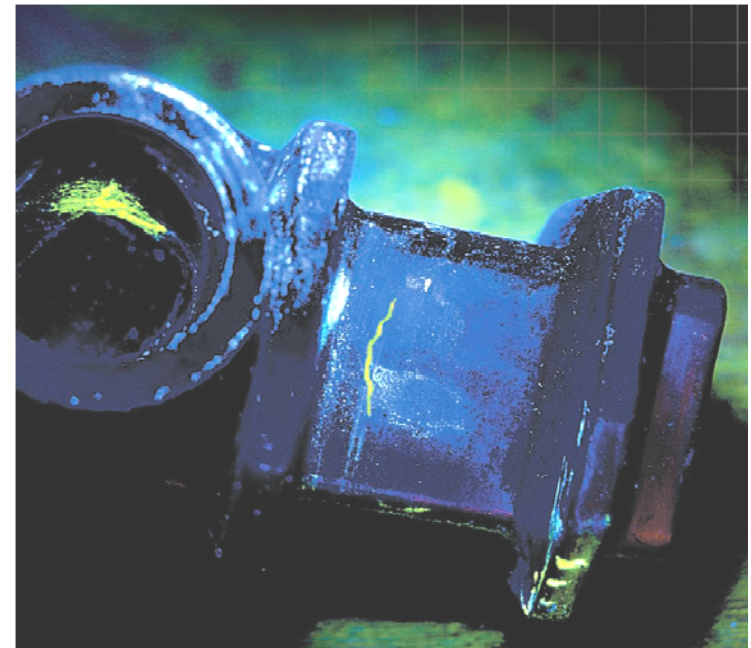
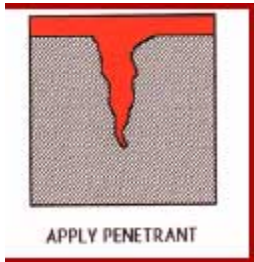
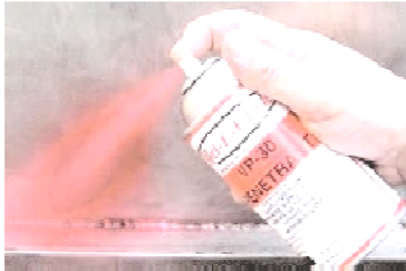

Odkrivanje razpok s penetracijo

# Kontrola zvarov - neporušne kontrole

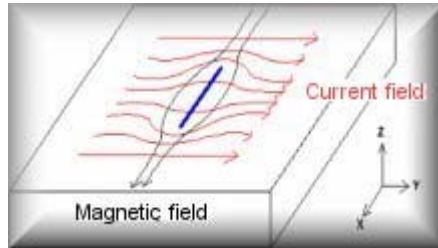

Magnetno polje

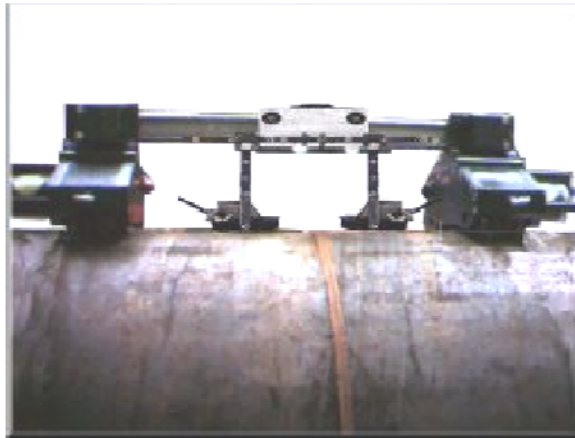

Magnetna kontrola



# Kontrola zvarov - neporušne kontrole

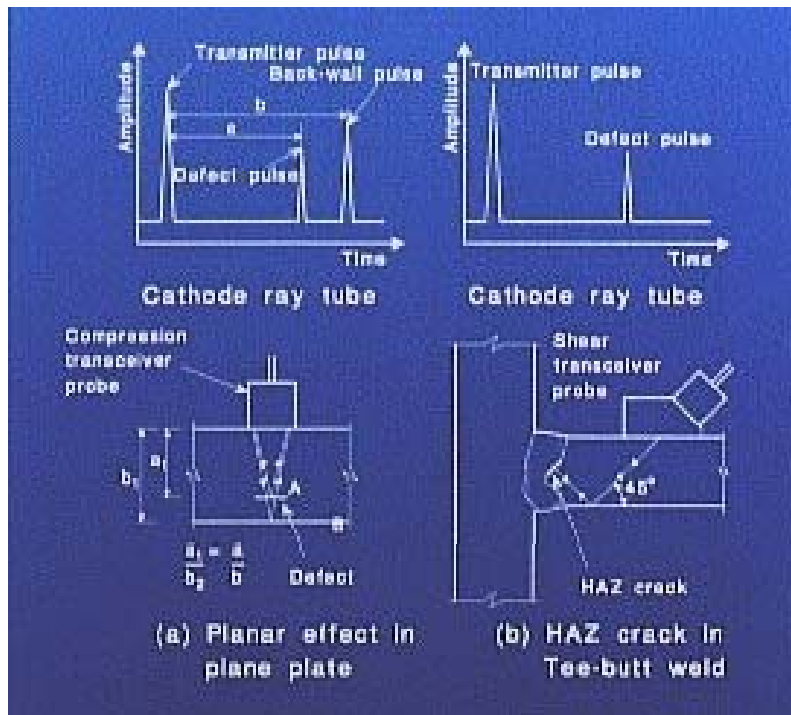

Kontrola z ultrazvokom

# Kontrola zvarov - neporušne kontrole

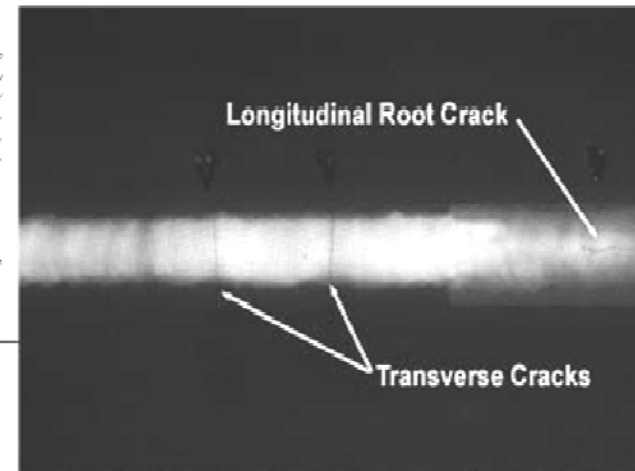
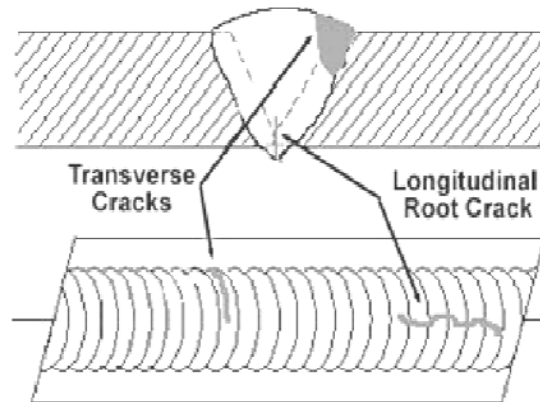
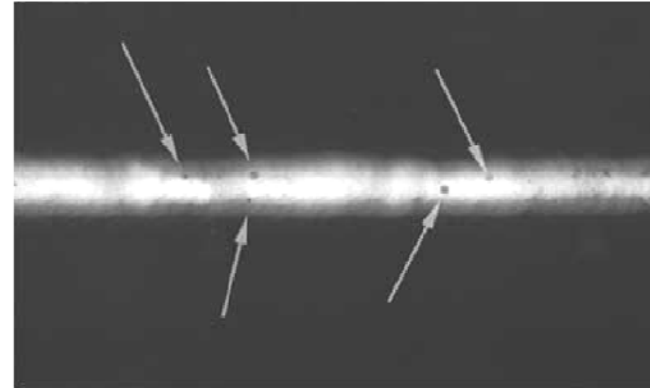
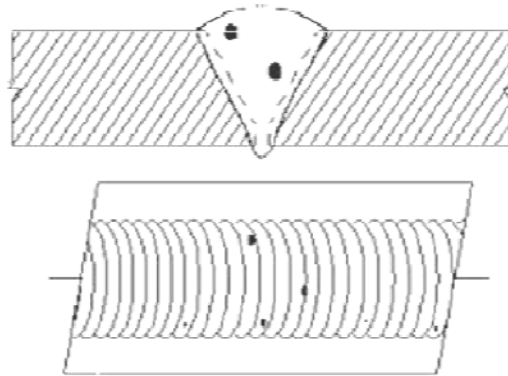

Kontrola z rentgenom